

BENCHCRAFTED

CRISSCROSS 14 Assembly & Installation Instructions

version July 2021

Package Contents

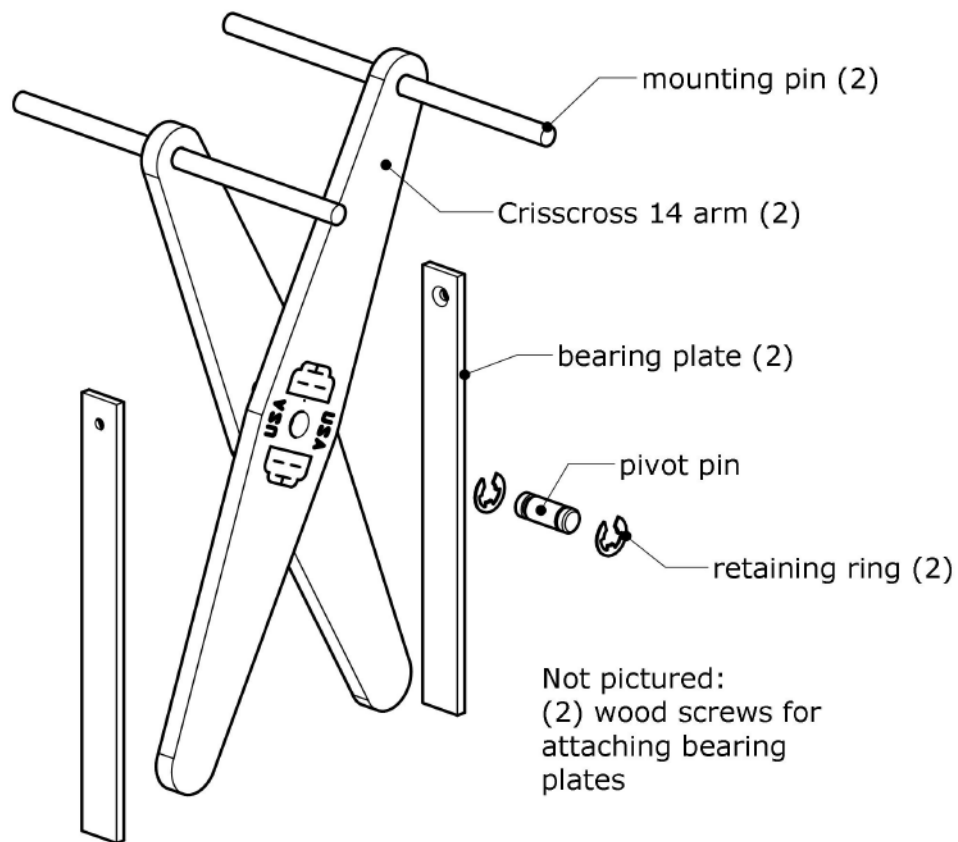

! READ ME FIRST !

Read and understand these instructions ***completely and thoroughly*** before starting the installation or cutting into your bench project. Only begin installation once you have the vise in your shop. There are variables explained throughout the installation process that will affect the first steps of the install. It's important that you read through the instructions from beginning to end to have a successful install.

UNPACKING THE CRISSCROSS 14

Be careful as you unpack and handle the components. Although we make every effort to ease all edges, being machined parts you may encounter a sharp edge or burr, especially if the product was handled poorly by the shipper. If you do, ease it with some fine abrasive paper or a fine file. Some components will have a rust preventative oil applied. You can remove this oil before installing the vise. Wipe it off with a clean paper towel, followed by a clean towel with a bit of mineral spirits. This will leave a light film of oil on the parts that will help prevent rust and keep the parts moving smoothly. Dispose of oily rags in the proper way.

ORIGINS OF THE BENCHCRAFTED CRISSCROSS

A popular mechanism for maintaining parallelism in vise jaws began appearing in the American patent record in the mid 19th century. There are also documented sources of this mechanism in the La Forge Royale catalog, Paris, late 19th to early 20th c. This device is basically two pieces or “arms” of iron or wood, equal in length, joined in the middle to create a pivot. The upper ends of the arms are joined to the bench’s leg and the chop via two pins, one for each arm. The resulting mechanism not only maintains a parallel opening, but also supports the weight of itself, the vise components, and the chop. The beauty of the mechanism is its simplicity. In modern times this mechanism has become known as the “St. Peter’s Cross”, taken from an early 20th c. publication describing it as such. To our knowledge, this is the only reference to this device by name. There has been some discussion about the history of this moniker, and the possible misnomer, since it was the Apostle Andrew that was crucified on an “X”-shaped cross, St. Peter being crucified on a “T”-shaped cross, albeit upside down. We eventually acquired a 19th century version of the St. Peter’s Cross, and used it to prototype our version, the Benchcrafted Crisscross. The Crisscross 14 was developed to fit into benches that cannot accommodate our full size Crisscross, such as the Moravian-style bench, adjustable height benches, or benches shorter than around 30 inches.

ASSEMBLING THE CRISSCROSS 14

The two arms join in the middle using the pivot pin and two retaining rings. We include an extra retaining ring in the package because they are easy to loose. During installation, it’s best to install just one retaining ring because you’ll be removing the pin and separating the arms a few times during installation. You can install the second ring after the vise is completely installed. Orient the Benchcrafted logo to the outside on each arm.

PLANNING YOUR INSTALL

The Crisscross 14 is a very simple mechanism. You can think of it as an entirely separate assembly from your leg vise hardware. Obviously it works flawlessly with the Benchcrafted Glide or Classic Leg Vise, but it also works with any other manufacturer’s leg vise hardware, metal or wood. It’s best to install the Crisscross 14 in the lowest possible position on your

bench leg. This allows you to also mount the vise screw in a lower position, giving you the greatest possible clamping capacity above the screw. Ideally, we like to keep about 1" of material below the mortise at the bottom of the leg and chop, but if your situation dictates that your mortise be open all the way to the floor, this does not present a problem.

INSTALLING INTO A NEW BENCH

Do the following operations with the leg free of the bench. Using the drawings at the end of these instructions, lay out the locations of the mortise, the mounting pins, and your vise hardware in your leg and chop. Your leg and chop should be at least 2-1/4" thick. This can be made from laminated stock. Make sure you don't position bench joinery, like the mortise and tenon that joins rails to the bench leg, in the way of the Crisscross 14, or your leg vise hardware, including the screw. The mortise is quite narrow, so there should be plenty of room for any bench joinery adjacent to the mortise. Drill the holes and excavate the mortises. The illustrations show the chop already cut to shape, but you should keep it un-shaped until the vise is completely installed and functioning properly. You can install the Crisscross 14 into any width leg or chop. We provide 8" long mounting pins to accommodate a wide range of widths. If your chop and leg is wider than this, it's okay if the pins are recessed in the chop. But if your chop and leg are narrower than 8", you'll need to cut the pins to length and smooth the ends. More on that later.

After cutting the mortises and drilling the holes, your leg and chop should look like this:

note that the leg here shows the counterbore for our Glide and Classic Leg Vises. Other vises may require different holes sizes.

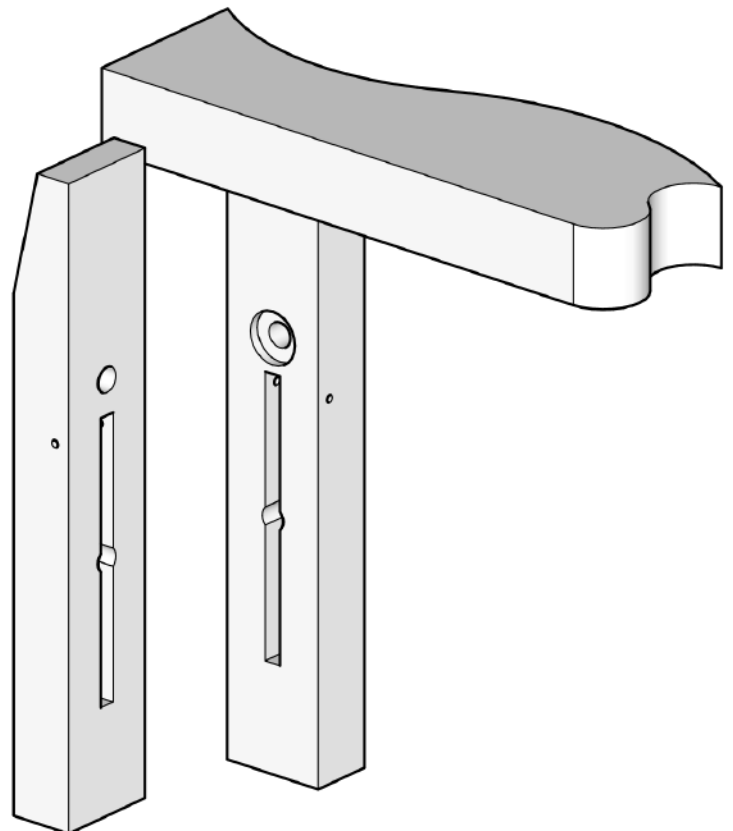

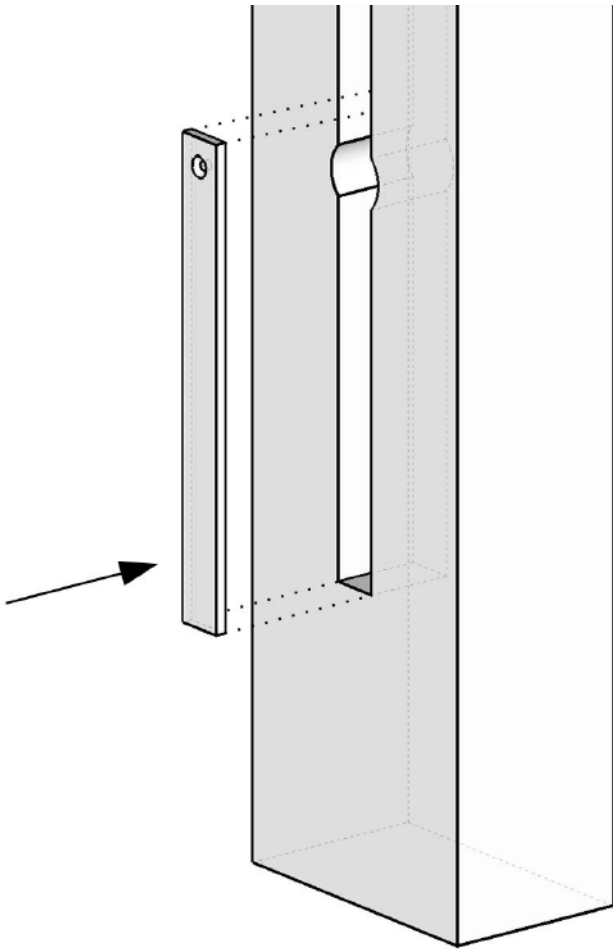

Install the bearing plates into the leg and the chop at the bottom of the mortises. They should slip into the mortise easily and rest on the end of the mortise and flatly on the bottom. Make sure you don't trap any wood shavings or chips behind the plate. The plate needs to be flat to the mortise bottom. Position the countersunk hole at the top, pre-drill, then drive the included wood screw to secure the plate.

Now install the arms into the leg and chop by tapping the mounting pins into the holes until they poke through into the mortise a little. Slip each arm onto the pin and continue to drive the pin until it enters the opposite side about an inch. You don't need to drive it

all the way through the leg at this time. Position the arms on their mounting pins so they are up against the mortise wall (not centered in the mortise.) Once the arms are installed, swing the arms together until the pivot holes line up, then insert the pivot pin.

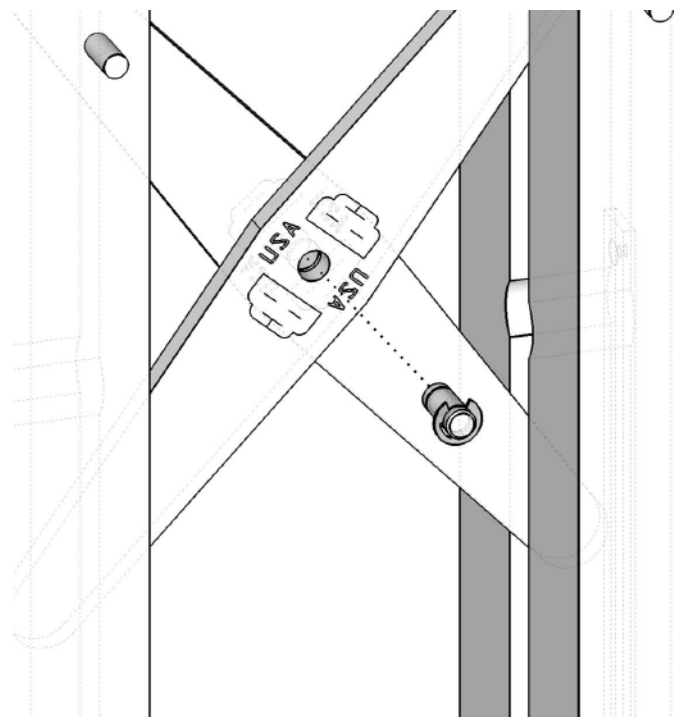
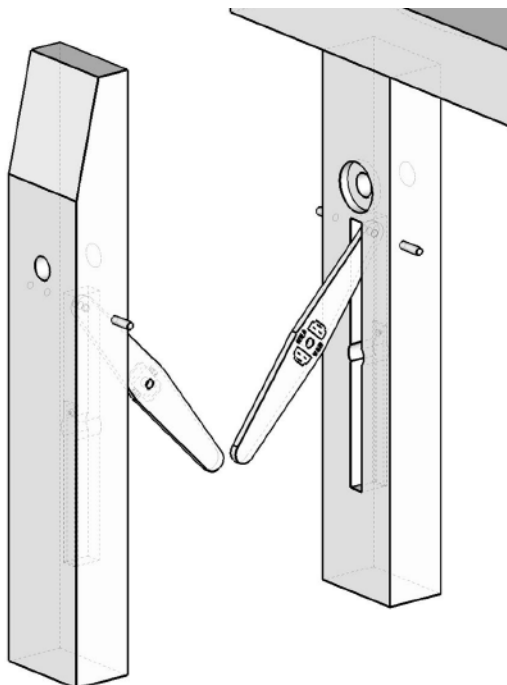

TEST THE ACTION

Clamp the leg upright in a vise or to a bench top so it's held securely. The chop should glide or "float" smoothly as you open and close the chop. If it doesn't, make sure the arms aren't rubbing tightly against wood in the mortise. Check the toe-in. Toe-in is when the chop contacts the very top of the leg first. You want some toe-in. It is essential for holding the work securely. If there is no toe-in (chop closes dead parallel to the leg), or negative toe-in (gap at the top) you should make some adjustments to get some toe-in.

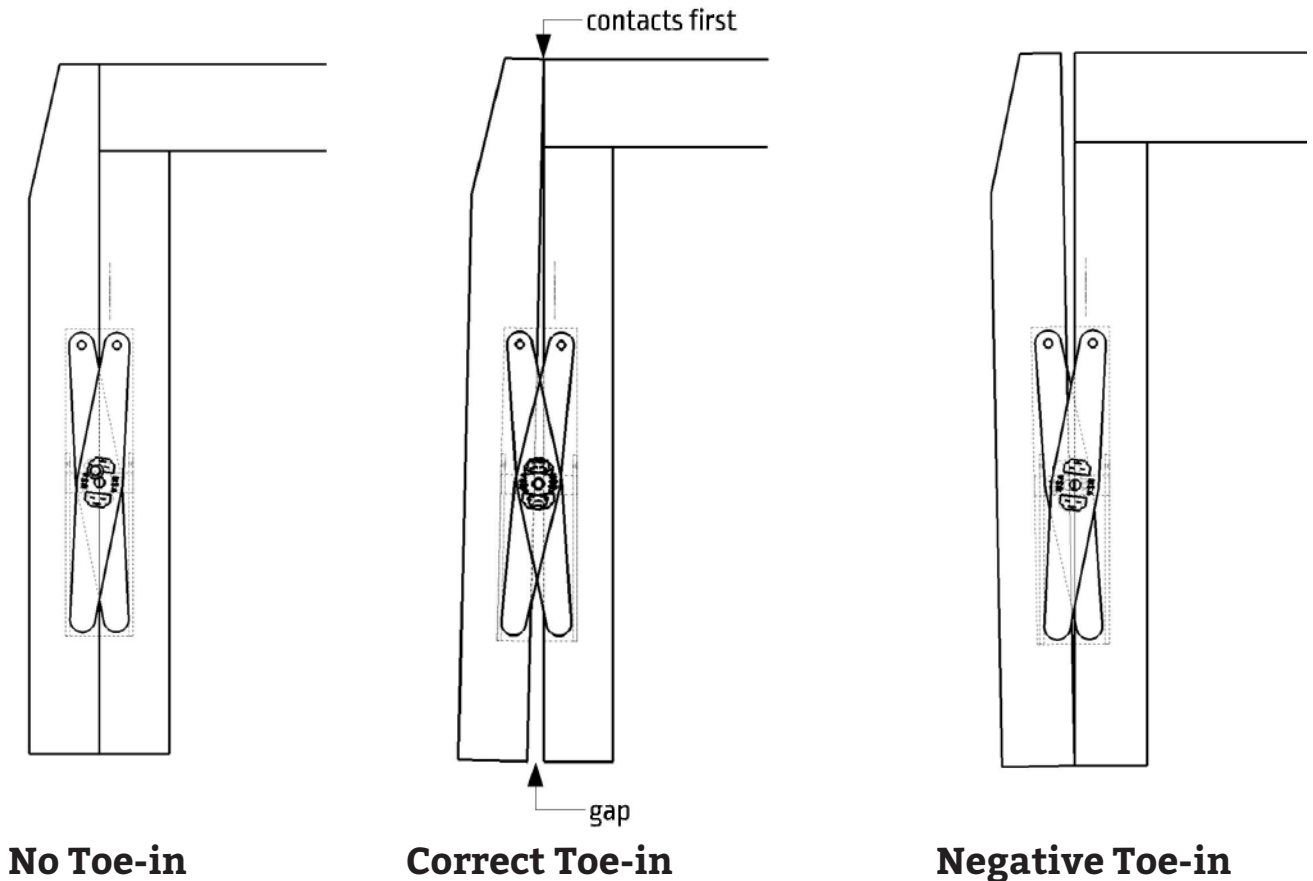

If you have too much toe-in, it can cause the screw's flange (on any vise) to bind on the shaft. To reduce the toe-in in this situation, you'll need to remove the bearing plate from the chop, then remove some wood from the mortise so the bearing plate sits deeper in the mortise. Start off with making the mortise 1-5/8" deep behind the plate (so adding 1/16" to the normal depth.) Reassemble and evaluate. Go deeper if necessary. If you have no toe-in, remove the bearing plate in the chop and slip a piece of veneer, or some dense cardboard behind the plate, this will tilt the chop and create some toe-in. If you have negative toe-in, the process is the same, add a shim behind the chop's bearing plate. If negative toe-in is excessive, you may have drilled your mounting holes too close to the inside faces of the vise. Plug the holes and/or reposition the Crisscross up or down (you'll have

to adjust the mortise length too) so you can drill correctly positioned holes. These methods work for adjusting your toe-in, but they can all affect the smoothness of the vise's action, especially if you go too far with an adjustment. If you find you have zero or negative toe-in, but the vise is operating sweetly, the best course of action is to dismantle the vise and plane a taper onto the inside face of the chop so it contacts at the top first. This gives you the toe-in you're after without affecting the mechanical action of the vise.

There is no magic number for determining the gap at the bottom for correct toe-in. If the jaw contacts first at the top, and holds well, you're golden.

TIP: To remove a mounting pin during installation, use a smaller pin (we use a long phillips screwdriver) to drive it out. The smaller pin will catch the hole in the Crisscross and keep the arm engaged with the chop/leg. You can now pull the smaller pin out easily since it's loose in the hole and safely remove the Crisscross arm from the mortise.

Now you can cut the mounting pins to final length and smooth the ends for a finished look. We like to chuck the pins in a drill and spin the ends against a piece of sandpaper.

INSTALL THE VISE HARDWARE

Mounting the Glide Leg Vise or Classic Leg Vise (or a leg vise from another manufacturer) is the next step. Please follow our instructions if you're installing a Glide or Classic Leg Vise. You can download these instructions directly from our website at any time.

If you're installing another company's product, or a vintage bench screw, we're adding a portion of our instructions below to assist in your installation.

POSITIONING THE VISE'S NUT

You need to position the vise's nut and fasten it to the bench leg so its in line with the movement of the Crisscross. Here's how you do it. With the chop completely closed and the screw's flange/handle mounted to the chop, thread the nut onto the screw until it gets close to the back of the leg. Make sure the chop is sitting at center left-to-right on the leg. Now with one hand, press hard on the vise's handle directly in line with the center of the screw. This will push the chop closed, forcing the inner surface of the vise handle to seat flat on the outside of the chop, flange or casting,

positioning the screw into a closely parallel orientation with the Crisscross (assuming of course that you've made the faces of your chop flat and parallel) As you're pushing in, you can observe the end of the screw raising up and finding its center within the leg's clearance hole. It must not touch any wood in the chop or the leg. This will slow down the action of the vise. If it touches wood, enlarge the hole until it doesn't. While still pushing in, tighten the nut against the back of the leg with your other hand until snug. If your vise chop has a lot of toe-in your screw will point more towards the floor. Keep this in mind during the next step. Crouch down and while holding the nut in position firmly with one hand (pressing against the back of the leg) slowly operate the vise. Try not to move the nut. If the vise operates smoothly, close the vise carefully until the nut is again snug against the back of the leg. If it doesn't operate smoothly, try shifting the nut around to find a spot where the vise does operate smoothly. What you're doing here is finding the sweet spot where the screw is resting gently inside the nut. This will allow the vise to operate at its peak.

When you're satisfied, snug the vise enough that the weight of the screw does not drop down and spoil the location of the nut, then mark the leg through the nut mounting holes for the mounting screws. Mark the nut itself so when you install it, its in the same orientation as before (a dot at 12 o'clock is what we do.) Now remove the nut, drill the pilot holes for the screws, and attach the nut Thread the screw back through the nut and test the action. The vise should now work sweetly. Sometimes, depending on how much toe-in you have, or how accurately you milled your leg and chop, the nut might bind on the screw when you operate the vise. This is usually caused by the nut being out of parallel with the screw. Loosening the screws that hold the nut to the back of the leg is usually the solution. These screws do not need to cinch the nut to the leg tightly for the vise to operate properly. Leaving the nut just this side of tight (so it can float around just a tad) will allow the vise to operate very sweetly.

Your Crisscross 14 install is complete. You can now unthread the screw from the leg, remove the screw and arm from the chop, then cut the chop to final length, do any shaping, attach Crubber (or leather/suede) and apply a finish of your choice. After reassembling the vise, install the other retaining ring onto the pivot pin.

WOODEN VISE SCREWS WITH TAPPED LEGS

If you're using one of these, you won't be able to shift around the position

of the nut to dial in the action of the vise. To install one of these vises, follow the next section for finding the vertical center of your screw's travel before installing your Crisscross 14.

RETROFITTING THE CRISSCROSS 14 TO AN EXISTING LEG VISE

If you're retrofitting the Crisscross 14 to an existing leg vise with a wooden parallel guide or a tapped leg, first study the drawings to make sure you have enough space, and your screw's position is compatible. If your chop isn't thick enough, or long enough, make a new one or laminate material onto the inside face to house the Crisscross mortise. If your existing chop has a mortise for a parallel guide, you may want to patch that just for looks. You may need to patch the hole in the leg as well.

Normally when installing a Crisscross, the vise hardware itself is installed last. It's easier to get the hardware aligned with the Crisscross travel than vice versa. But since you're retrofitting a Crisscross, you'll need to find the vertical center of your existing chop, screw and nut, then layout the location of the Crisscross based on this location. Once the Crisscross is installed, the vise screw needs to be travelling parallel to the movement of the Crisscross. If your screw is off a few degrees (tilted up or down in its nut) your vise may at worst bind, or at least not work smoothly. The Crisscross completely supports the weight of the vise and chop, so to take advantage of this smooth movement, you also want the screw to turn freely in its nut, and travel in a straight line, parallel to the in-out travel of the Crisscross. If a new chop is required for your retrofit, you could treat your install as new, and simply follow the instructions from the beginning. Make sure you layout the hole in the new chop for the screw based on the location of the existing hole and nut in your bench leg.

Finding vertical center in an existing chop

So now that you know that the screw travel and Crisscross travel need to be parallel, here's how to find the vertical center of your existing leg vise hardware in its chop. Close the vise almost all the way, leaving it open just enough so the chop isn't tight. Mark the side of the chop and the side of the leg with a short, horizontal line--mark both the chop and the leg at the same spot near the inside faces of the vise. It doesn't matter where vertically, somewhere close to the top is fine for convenience. The weight of the chop should be pulling down on the screw. This represents the lower posi-

tion. (if your vise has a parallel guide, make sure you remove it from the chop before this procedure.) Now, pull up on the screw's handle and watch the mark you made on the chop--it should move up from the corresponding mark on the leg. Transfer this upper position to the leg by drawing another horizontal line. It should fall above the lower line on the leg. The leg should now have two marks on it. Now tighten the vise slightly so it will hold its position as you make the third mark. Depending on where the chop tightened up, adjust the vertical position of the chop (tap down or lift up) until the mark on the side of the chop is centered between the two marks on the leg. The screw is now vertically centered in the nut. It's important that during this process the screw does not contact wood as it passes through the clearance hole in the leg. If it does, enlarge the hole in the leg, so with the vise vertically centered the screw does not contact any wood. You DO

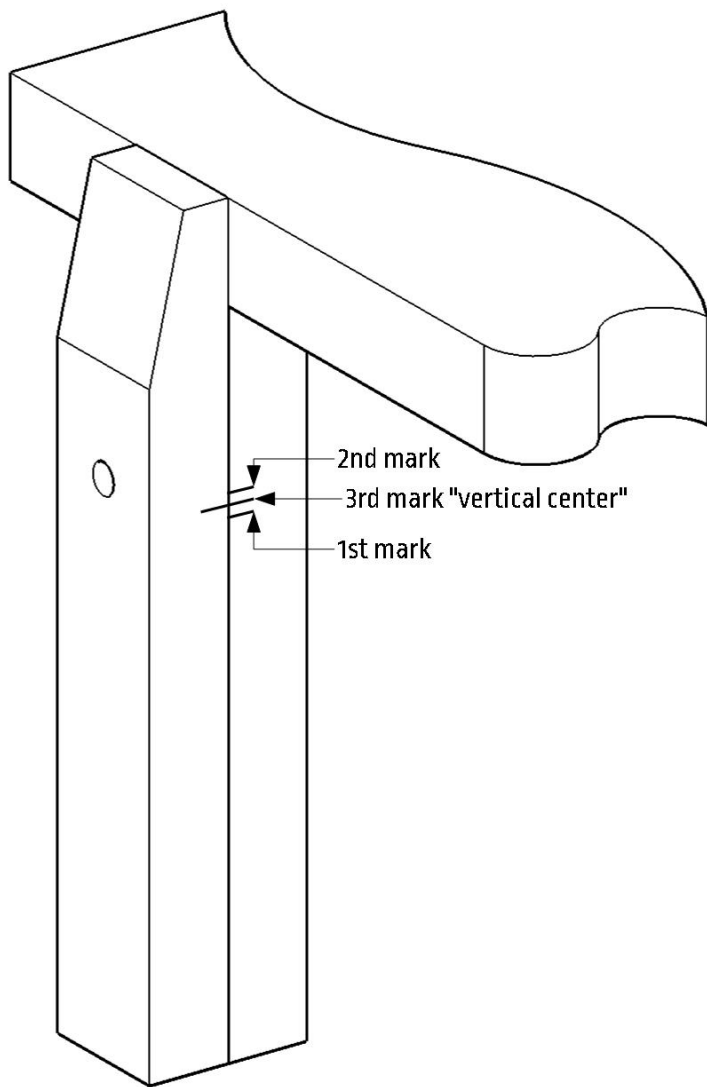

NOT want the screw to rub on the inside of the hole. (If your leg is tapped wood, you won't be able to do this.) With the chop still tight, extend the line on the chop across to the side of the leg, it should be centered between the two marks. Open the vise, then continue this line across the inside face of both the chop and leg. This is your datum, or reference line. When marking out the position of the Crisscross mortise, always measure and mark from this line equally on the chop and leg. This will ensure your Crisscross is perfectly aligned with your vise screw. Do not measure or reference off the ends of the chop or leg. And equally important, DO NOT change the position of the nut on the back of the leg. If you do, you'll have to find vertical center again.

Now that you have your reference marks, you can lay out and install the Crisscross 14 as outlined in the beginning of these instructions at "Installing into a new bench."

TROUBLESHOOTING

Binding or less than smooth movement

This is usually caused by the screw not running in line (parallel) with the in-out travel of the Crisscross. The easiest way to correct an out of alignment screw is to reposition the nut. Repeat the process described in "Positioning the vise's nut" You'll need to rotate the nut so you can drive the screws into fresh wood. Also check that your Crisscross mortise is clean and free of chips and that the ends of the mortise are long enough. The arms should only contact wood in the chop and leg very slightly on the sides of the mortise. This doesn't affect the smoothness of the vise, but if the arms are rubbing at the top of the mortise above the mounting pins, you'll need to remove material from this area. Same at the bottom of the mortise, the arms should have some space below their ends with the vise completely closed.

The mounting pins are not parallel with each other

If you've mis-drilled the holes for the mounting pins, you'll need to plug them, then redrill the holes in the proper location. If you plug the holes with on-size dowel it may be difficult to redrill the holes because your bit will want to wander (even in a drill press) while drilling partially through the end grain of the dowel and the edge grain of the leg or chop. You could reposition the holes above or below the plugged holes to get access to fresh wood, or plug the holes with much larger dowel (like 3/4") so you can drill into only one type of grain.

MAINTENANCE

The Crisscross 14 arms are made of cold rolled steel and require no maintenance other than to keep the mechanism clean of dust and grime. The parts can rust of course, so take necessary precautions to prevent such. But even if they develop some surface rust, it's purely cosmetic. It won't affect how the vise functions. You can wipe the arms down with a light oil (what you use on your hand planes is a good choice) to help prevent rust. A few small drops of oil on the pivot and mounting pins every few months will help keep the mechanism operating smoothly.

As with all our products, we are happy to provide technical support, free of charge via email. We want your vise to operate perfectly and we're here to

make sure you get it installed to your satisfaction. Write us at technical@benchcrafted.com.

Thanks for purchasing the Crisscross 14!

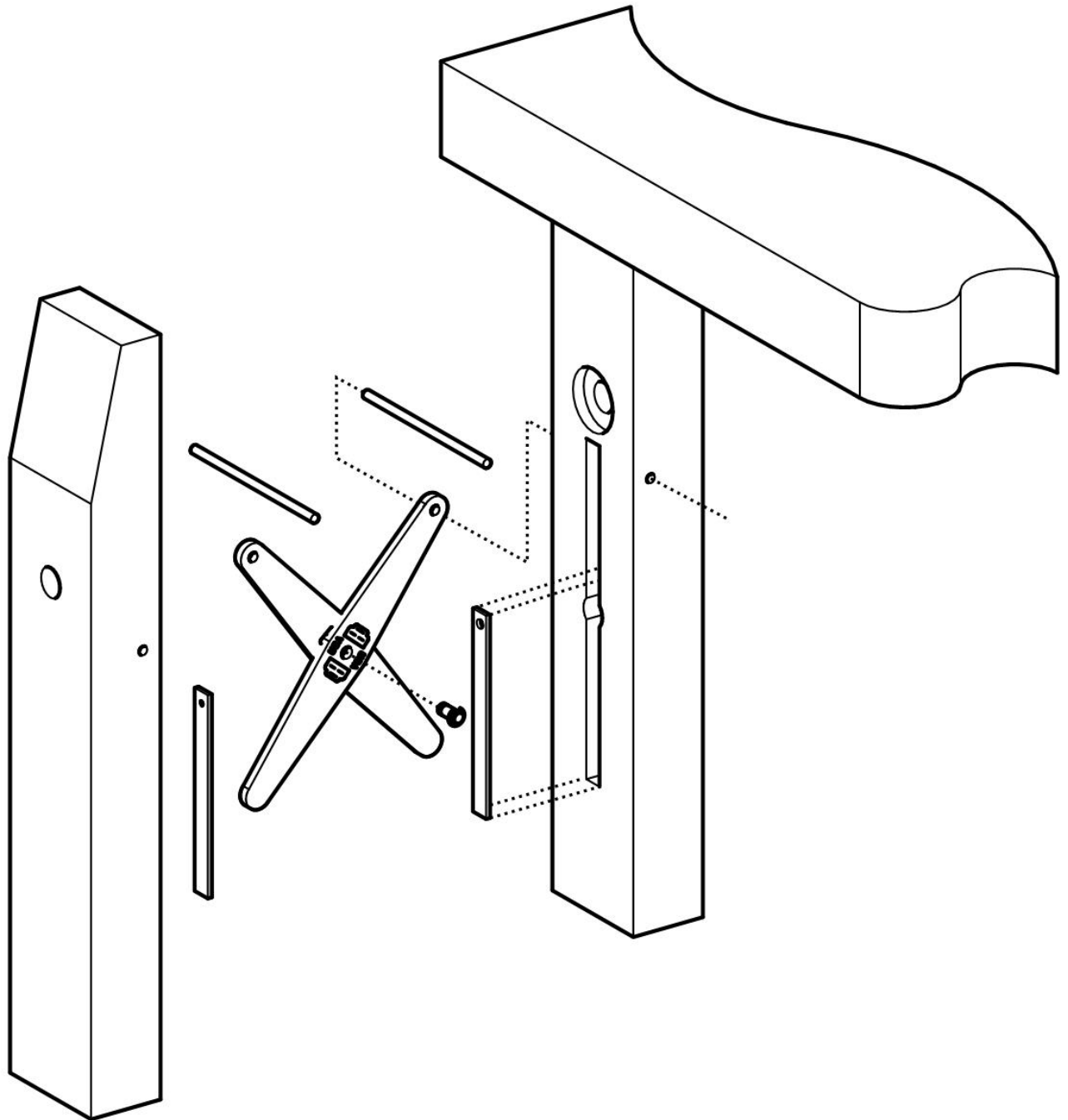

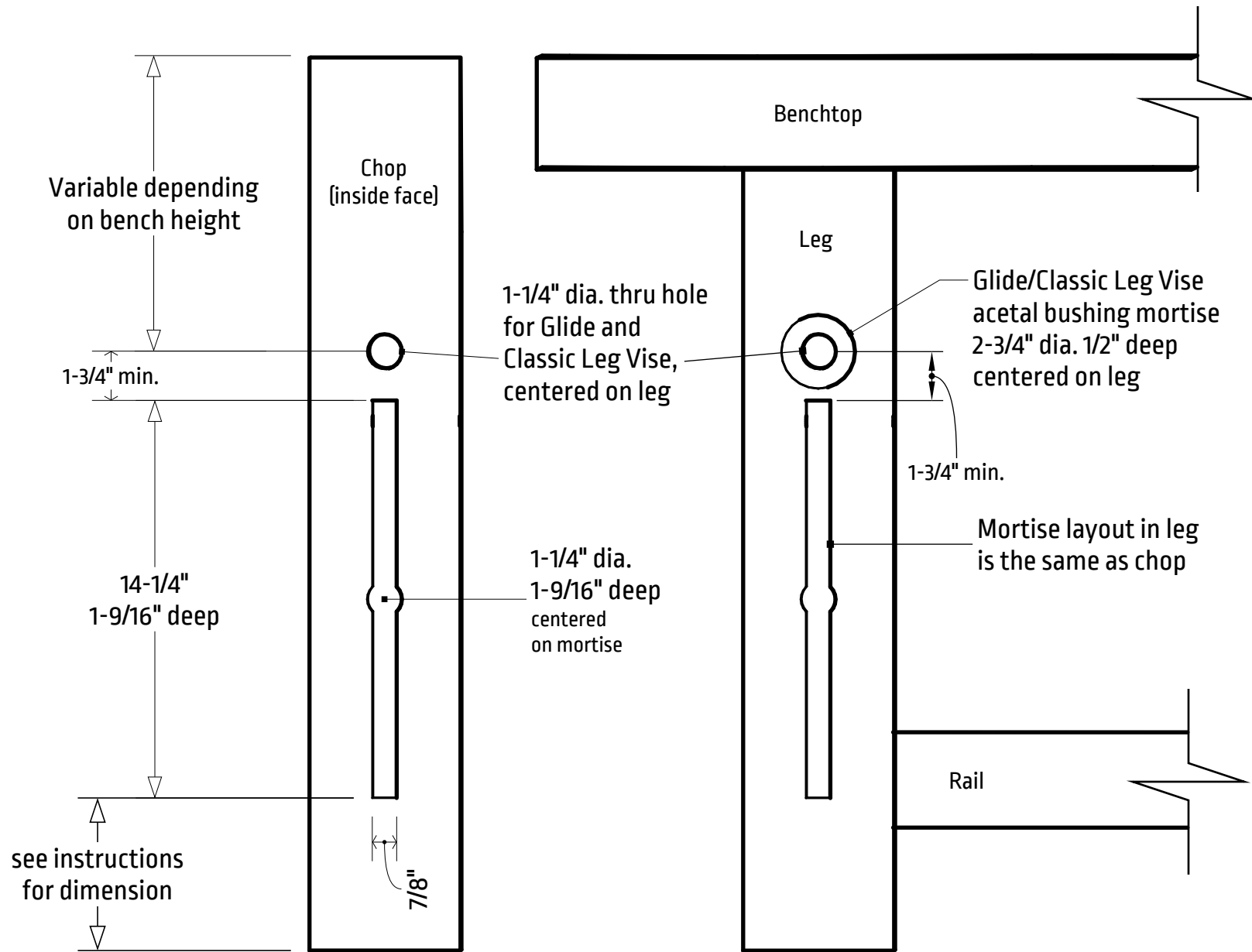

Note: Mortises are centered horizontally on chop and leg

BENCHCRAFTED CRISSCROSS 14

mortise layout p.1



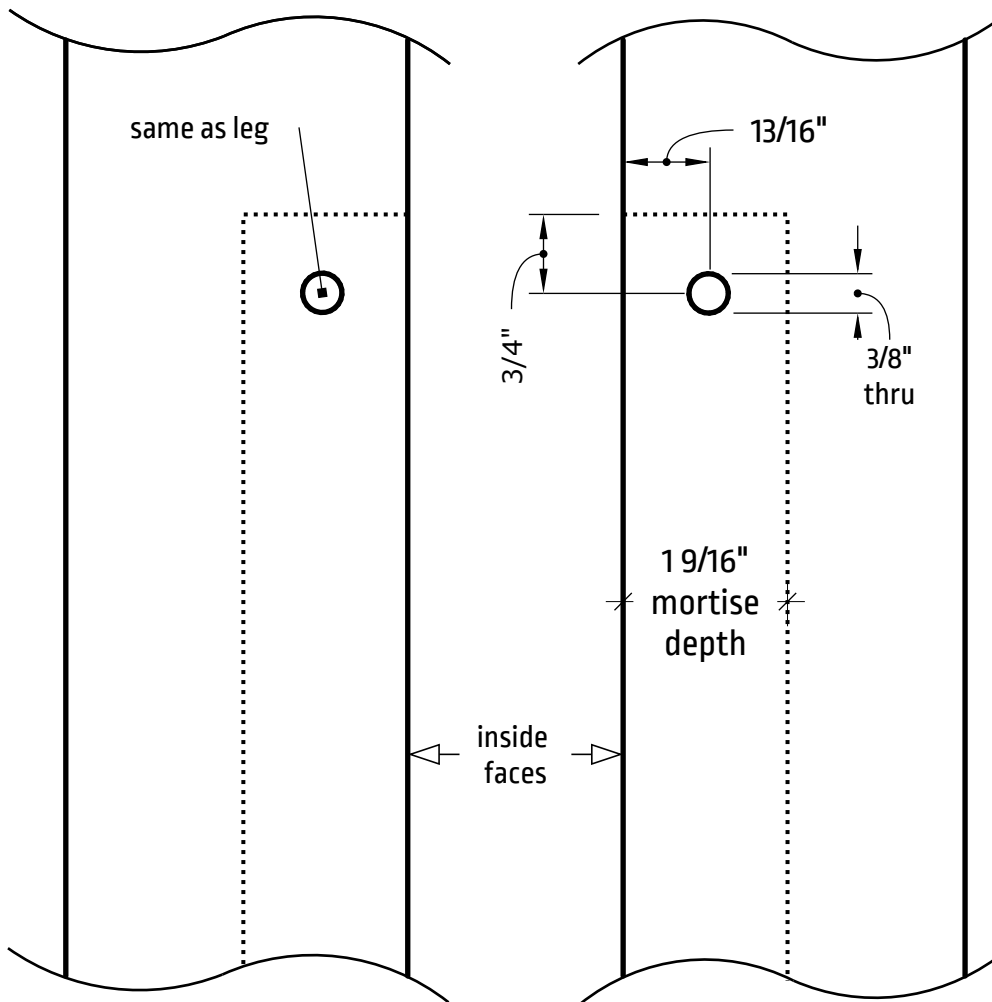

Chop

Leg

Detail

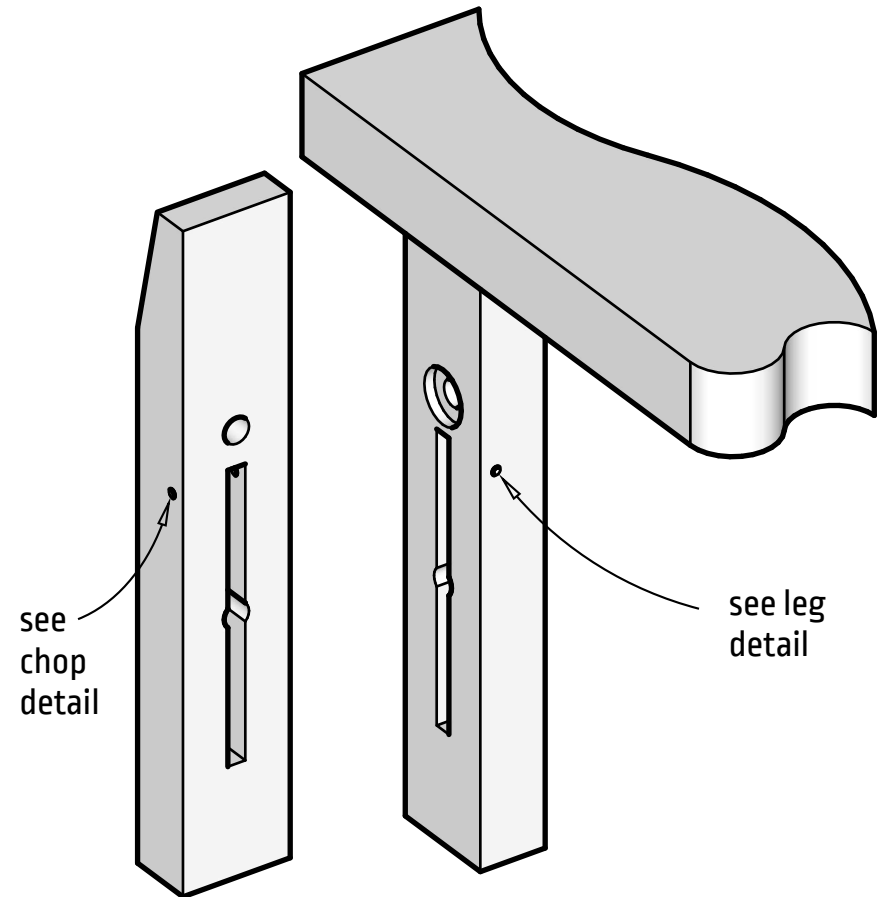

BENCHCRAFTED CRISSCROSS 14

mortise layout p.2

