

# Building a Roubo-Workbench

by Guido Henn (Translation by Brian Anderson)



Legvise



Wagonvise



Plane- or Saw Stop



**Step-by-step building instructions:**

- all important information
- numerous, detailed photos
- 2D- and 3D- drawings

Contents	Page
Contents and Introduction	2
Special features	3
Dimensioning, jointing and glue-up	6
Mortises and tenons	9
Crisscross parallel guide	12
Vise screw hole and nut	14
Frame sides glue-up	15
Bed bolt installation	16
Benchtop dovetail joints	17
Cutout for tail (wagon) vise	19
End clamp drilling and installation	20
Tail vise installation	22
Post mortises	24
Leg vise screw, chop, and crisscross	25
Bench hooks and deadman	28
Shelf and center slot board	30
Drawings and dimensions	32

## The Base for Perfect Woodworking

As the old saying goes, a man absolutely should have done three things in life: fathered children, planted a tree, and built a house. To this list a woodworker would surely add: to have built a great workbench. Everyone who takes woodworking seriously, sooner or later dreams of building with his own hands a bench that is truly his.

I recently had the luck and the honor to build such a bench, a very special bench of a type that is impossible to buy anywhere. It is based on an old design from the French master carpenter and writer André Jacob Roubo (1739 - 1791).

Roubo detailed the basic form, which at first glance is rather unusual, in his book "L'Art du Menuisier" (The Art of Joinery). An American family firm, Benchcrafted, has developed and produced a set of perfectly adapted hardware for this type of bench. The quality of design and production in these vises is really very impressive. The ease of use, fit and finish, and all around elegance of the components' form and function add a great deal to the appeal of this workbench.

The first time you spin the massive hand wheel and watch how the solid, heavy chop of the leg vise effortlessly, almost weightlessly, opens and closes, it will very difficult to escape the spell of this workbench.

I know most of the different types of workbenches, and have done both restorations and new builds, but I found none of them as fascinating as this Roubo bench. The massive construction, about 150 kilos, makes this bench extremely well-suited and a pleasure to use with hand tools. Nothing moves or wobbles even during strenuous hand planing, and the 104 mm-thick top does not move a micron even when chopping fat, deep, mortises.

The bench also offers a wide variety of work-holding possibilities - that you can securely fix work pieces of almost any dimension or various



types of jigs and benchtop tools in the most convenient position - makes this bench very well-adapted for woodworkers using heavy machinery as well.

Just in general, the many wonderful small details of this bench set it apart from more conventional workbenches. If you have been on the lookout for a solid bench for fine woodworking, then your search ends here.

Let's have a look at the following sites and the video at [fine-tools.com](http://fine-tools.com) to learn the attributes of this inspiring workbench.

These instructions will outline all the important steps in the construction of this dream bench. All the fittings and accessories can be found at the internet shop of Fine Tools Berlin ([www.fine-tools.com](http://www.fine-tools.com))

I hope that your build of this Roubo workbench will be a success and a pleasure.

Sincerely

**Guido Henn**

Text, Photos, Drawings and Layout:  
Guido Henn, 53902 Bad Münstereifel,  
Germany  
[www.hobbywood.de](http://www.hobbywood.de)

© 2014 by Guido Henn

All Rights Reserved. This pamphlet is copyright protected. Any use of the text or photos or design of the pamphlet beyond the cases regulated by law must be approved in writing by the writer. The described methods, techniques, suggestions and recommendations were carefully prepared and tested by the author. Nevertheless there is no guarantee implied or expressed. The author accepts no liability for personal injury, or damage to property or other assets.

**Building a workbench based on the illustrations by  
André Jacob Roubo (1739 - 1791)**

(optimized with hardware by Benchcrafted)

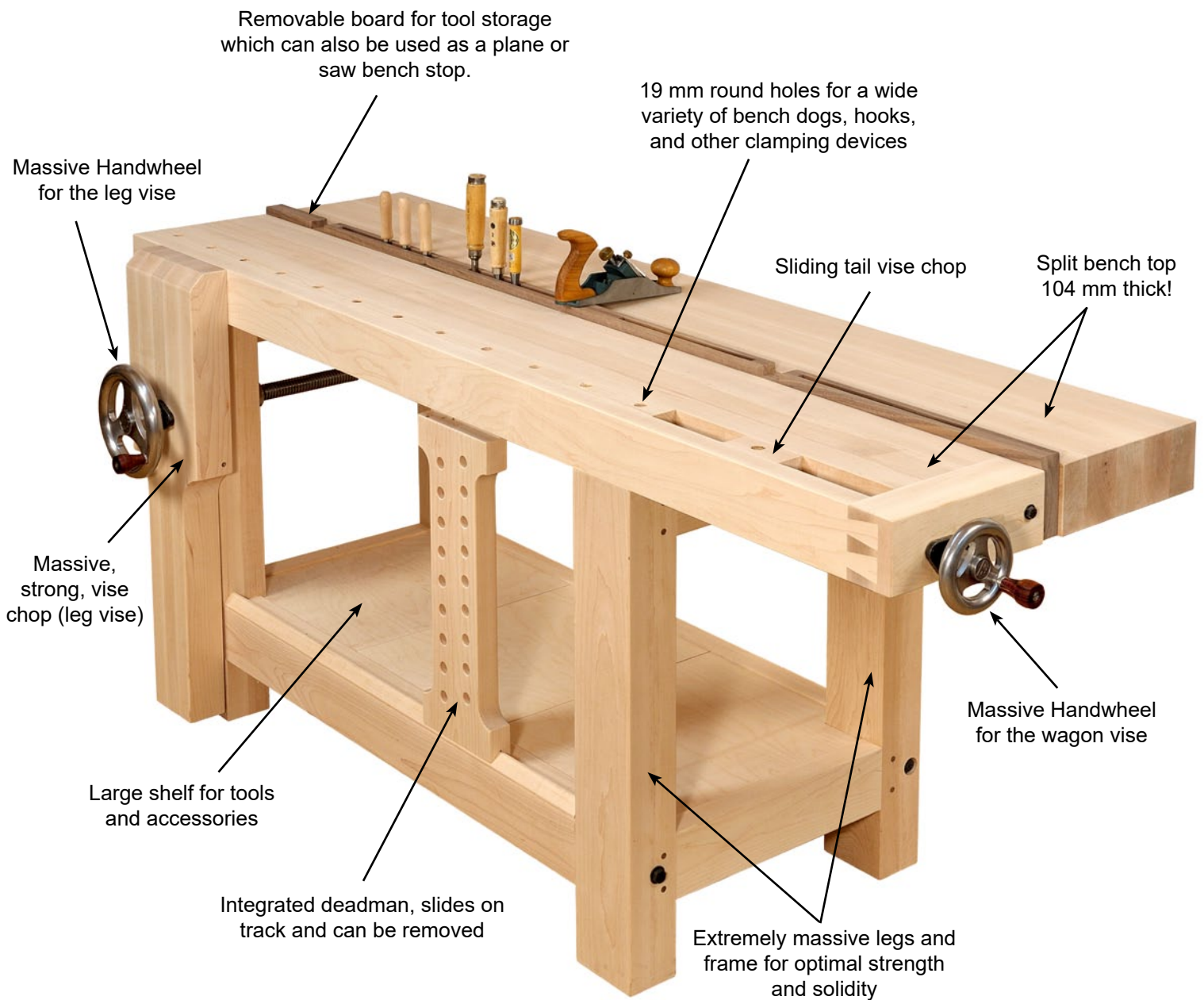



The Highlight of this bench is the extremely smooth and quickly adjustable leg vise, which is capable of very high clamping pressures.

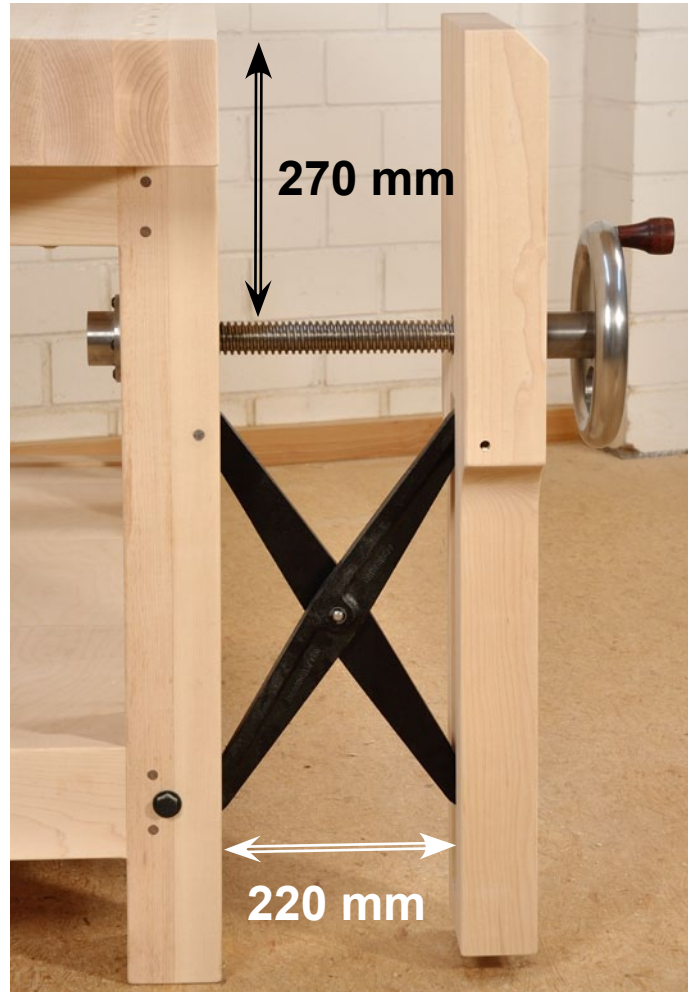

The maximum clamping width, of 220 mm and clamping depth of 270 mm leaves most other regular face vices in the dust.



If you need to clamp longer boards in the leg vise, there is an integrated sliding deadman that can be moved steplessly between the two legs to solidly support the workpiece along its length.



The deadman can also be removed and, along with any other tools, be stored on the large shelf supported by the rails joining the base of the legs.



The tail vise can be used to clamp workpieces up to 310 mm wide and 45 mm thick.



Longer and thicker workpieces can be clamped to the bench top using round brass bench dogs.

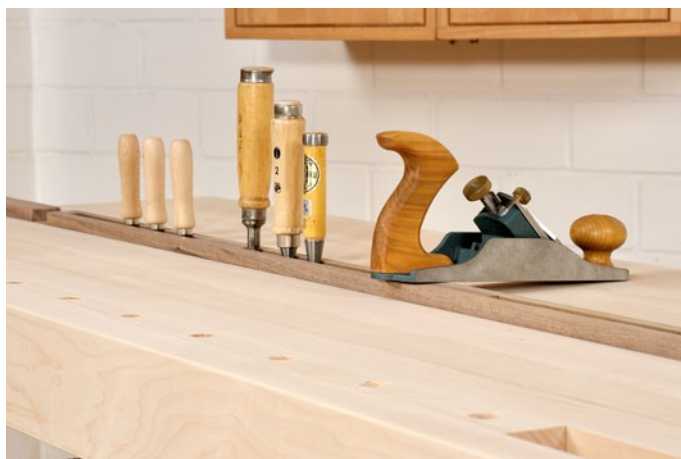

A slotted board fits the slot between the two sections of the bench top. Chisels, saws, etc. can be temporarily stored in the slots while in use, and the board makes a handy place to set planes so that their irons are protected and do not mar the surface of the top.



Because the board stands 15 mm proud of the bench top, it can also be used as a saw stop, while cutting the shoulders of a tenon, for instance.



The projecting board works equally well as a planing stop, to pare the cheeks of a tenon using a rabbit plane, for instance.



The board is simply placed loose in the slot, and can be easily removed and set aside. F-clamps can then be inserted into the empty slot between the two sections of bench top to fix work pieces or other bench top accessories in place.

## SECTIONING, JOINTING AND GLUE-UP

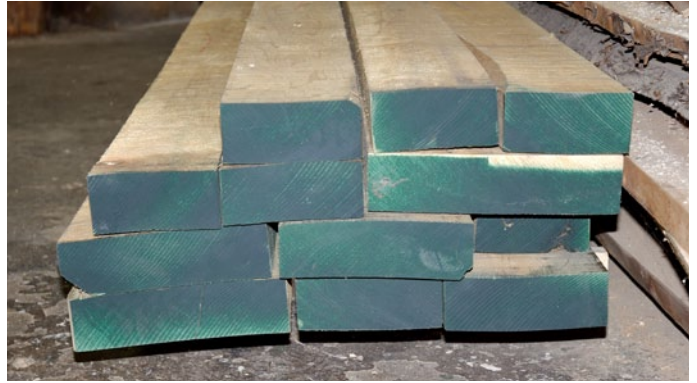

To build a Roubo workbench you will need between 0,35 to 0,4 of a cubic meter of good quality, clear hardwood dimension lumber. If you use rough-sawn planks with the live, or forest, edge intact, or a species of wood with a lot of sapwood (like oak, for instance), then the volume of wood needed can be significantly higher. For my workbench I chose “hard maple” dimension lumber from Canada or the United States, which one can readily find in a well-stocked lumber yard. This wood is very hard, it “works” much less than beech with changes in the ambient humidity. Its light color is an advantage for workbenches, and it does not have deep pores, like oak or ash, for instance. The price for wood suitable for a bench like this can vary quite significantly depending

on the dimensions of the wood purchased. The thicker the planks, the more expensive they will be. I chose 65 mm boards for the bench top, and 52 mm planks for the frame. There was a difference of 200 euros in the cost per cubic meter between the two thicknesses. So it can be worth it to buy thinner stock for the whole bench. But then you must remember that thinner stock will require more jointing and glue up.

There is also the question if the thinner 52 mm stock will be as straight. Can you, for example, expect to get from six planed planks a section of bench top 285 mm wide. In that case you would have to figure on planing a maximum of 4 mm of each plank - which on 2-meter long planks would be a really close thing.



Sectioning the planks can easily be done with a good hand circular saw using a guide rail. Lay the planks on plenty of blocks or saw horses. The boards must be supported along their length so that the cuts can be made without the danger of the off-cuts falling to the floor or having their weight bind the saw in the cut! If you can also clamp the boards in place, the sectioning work is easier, safer and more precise. Be careful to cut the stock about 50 mm longer than needed. It is also important to closely examine the ends of the boards. If there are any cracks from the drying and seasoning process, then you will need to also take those into account when dimensioning your lumber.

Finally, the hand circular saw with guide rail is also used to cut your stock to the correct width. During this step, you must also be careful to allow a little extra wood so that the boards can be planed and jointed (5-7 mm). If you have a table or panel saw in your workshop, obviously you can use those saws to cut the boards to width.

## SECTIONING, JOINTING AND GLUE-UP

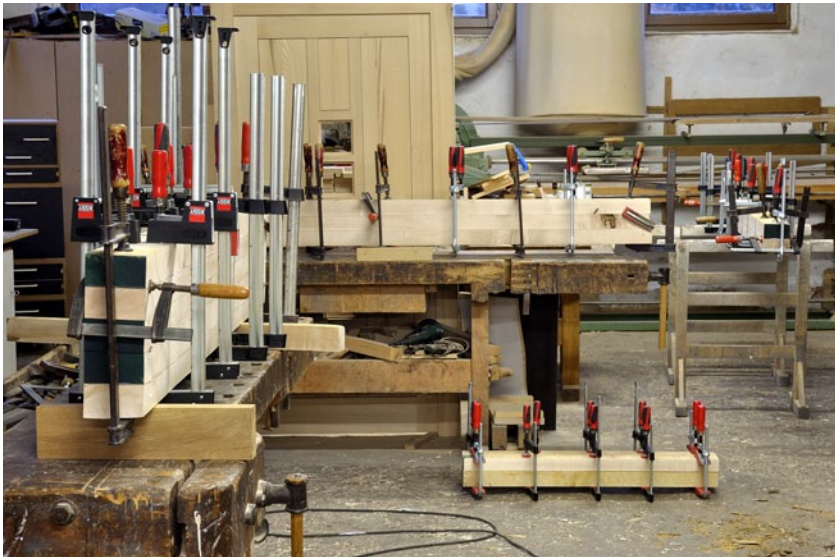

The main challenge when building this bench is the exact planing, jointing and glue-up of the bench top and posts. Besides a good jointer/thickness planer, you will need, as shown in the photos, a significant number of large and strong clamps. Because suitable wood in the sizes required is quite heavy, a strong assistant is highly recommended during the planing and glue-up steps when building this bench. When you have successfully met this challenge, then the rest of the construction will be like a walk in the countryside, or perhaps, better put, a short mountain hike!



As we have already mentioned, a good number of big, solid F-clamps are an absolute must when building this workbench. In order to glue up the posts for instance, you will need at least 10 clamps in order to properly close up the glue joint. Two lighter clamps are used to make sure that the two planks do not slide around during clamping the piece up. It is best to use a toothed glue trowel or spatula to get a consistently thin and even coverage on the boards. Many glue manufacturers recommend, for hardwoods, that both sides of the joint be coated with glue. If you need to do this, it is extremely important to use a very thin coat on each board. If it is too thick, then the excess glue will be squeezed out around the joint. This makes a mess and takes time to clean up, but far worse is the fact that it becomes very difficult to achieve a strong and tight glue joint. You will know you have spread the right amount of glue if after the clamps are tightened, you have a small, even bead of glue squeezed out around the entire joint. It is a good idea to practice this process on the posts, so that you have it mastered when you start glueing up the longer bench tops.

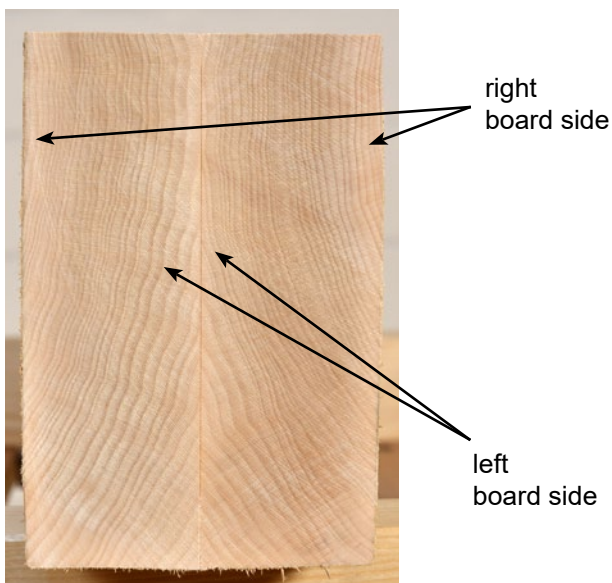

Be careful during glue-up to follow the usual rules for these kinds of laminations - heartwood on heartwood, and sapwood on sapwood, for instance. Very important also, with the posts for instance, is to always glue the "left" sides of the board together. That is to say, since boards always shrink more, or cup towards, the side toward the outside of the tree, this helps keep the glue line nice and tight as the wood moves with changes in humidity.

Info: The "left" side is that toward the bark of the tree, and the "right" is toward the heart (the middle of the tree trunk). (see also the arrows in the photo)

## SECTIONING, JOINTING AND GLUE-UP



If you joint only the two sides of the boards that you want to glue together, you do not have to use clamping pads to protect the wood. The still-raw outer sides can then be planed to their final dimensions after the glue has fully cured (overnight, at least! see photo above) To do this you first joint the wider side of the post, ...

... and then press that side against the fence to plane the narrower side flat and square. In this way the two sides are flat and square to each other. Then you run the post through the thickness planer, first the narrow side, and finish by planing the wider side to the correct dimension in the thicknesser.

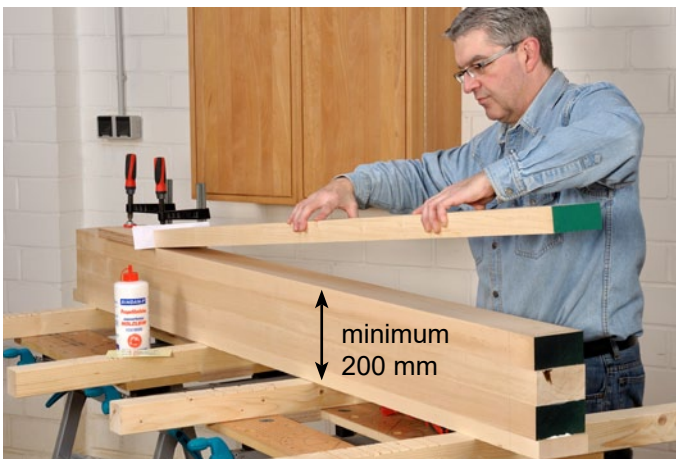

The rear section of the bench top is simply glued up out of a number of two-meter-long (plus any needed off-cut material on the ends) boards to get a width of at least 285 mm. The front section is a little more complicated. With this section you glue up a section of at least 200 mm width in the 2 m + boards. Then to the clean, square and jointed front side of the 200 mm wide part, you glue another board, exactly jointed and thickened to its finish dimensions of 45 mm thick, 104 mm wide, and at least 1492 mm long. This short board will create the slot for the tail vise. It is best to leave this piece about 50 mm longer than needed and just saw one end so that it is ...

... exactly square. So that this board can be glued exactly at the proper point, and can't slip, clamp an auxiliary board on the front edge of the top to form a "stop" for the board. It is important also to put a strip of paper between the auxiliary board and the bench top to make sure you don't inadvertently glue the auxiliary board to the top. Then you use some clamping pads under the clamps and use enough of them to make sure the joint is tight all along its length. Then give the glue time to cure properly, overnight at least.



## MORTISE AND TENON JOINTS FOR THE FRAME



To cut the tenons needed to join the workbench's frame, you can, naturally, do it entirely by hand or use the aid of machines. With a jig like the one shown in the photo, the 50 mm long tenon cheeks can be cut safely and very precisely on a Festool "trimming" table saw like this. But it can also be done with a regular table- or panel- saw using a similar type of shop-built jig. The first step is to cut the two 50 mm-long tenon cheeks.



The rail is laid flat on the saw table and the tenon's shoulders are cut.

**Important tip:** In this bench, there are mortise-and-tenon joints in a few different dimensions. So it is important to double check each piece and each joint to make sure you have taken the proper dimensions and orientation from the plans. It is fairly easy to lose track of where the part fits in the overview, and get the wrong measurements for the individual parts.



A more precise way to cut the tenons is to use a router, or better, a router table, as shown in the photo. The router table must have an accurate miter gauge. The bit should be relatively large, with a diameter of at least 30 mm. When using these machines, it is best to rough-cut the joint with a saw, leaving just a little bit of extra wood, and then use the moulder or router table to finish the joint. This saves wear and tear on the router bits, or cutters, and saves on sharpening costs.



You can get remarkably precise and clean cuts for tenons using a rabbeting cutter, with interchangeable blades, or cutters, like the one shown in the photo, on a solid router table. The cutter shown has a diameter of 50 mm, and a cutting height of 30 mm. In this way you get a very high rotation speed, and so can achieve a clean cut that you would expect from a heavier milling machine. This gives a lighter table tool more of the feeling of a heavy duty moulder/shaper.

## MORTISE AND TENON JOINTS FOR THE FRAME

---



The tenons are also cut in on their edges slightly. Again here, the best way is to use a hand saw to rough-cut the joints, ...



... leaving just a bit to be trimmed to their exact dimensions on a router table using the miter gauge.



Using a 16 mm straight cutter (cutting depth 50 mm) and a router, you can then machine the mortises. In order to make sure the router cuts the mortise, and doesn't slip or get pulled out of alignment, it is best to add a second parallel guide, or fence, to the setup. Depending on the model of router you use, sometimes you will need to get longer steel rods. It is also fairly easy to build a jig yourself to achieve the same accuracy of cut (Info on this type of jig can for instance be found in my "Handbuch Oberfräse" ISBN: 9783866309494). When cutting these kinds of slots, it is also important to securely clamp stop blocks at both ends of the workpiece so that you do not over-cut at either end.



The rounded ends of the mortises are then squared off using a chisel. Alternatively you can also carefully round the ends of the tenons with a file to get a good fit. Another practical solution is to use an 8 mm round-over bit on a router table to shape the tenons to fit.

## MORTISE AND TENON JOINTS FOR THE FRAME



The upper ends of the posts also have a tenon to join them to a mortise that will be cut into the underside of both pieces of the benchtop. These tenons can also be cut very precisely on a router table. Because these tenons are not exactly centered in the ends of the posts, you must take care to precisely layout and mark their position according to the plans.



The posts should then be set together on the workshop floor and carefully checked against the plans and each other before you start cutting. In this step, it is very easy to make a preventable error, so it is better to check one too many times, than one too few!



To join the two back posts to the long back rail, you first use the drill press and 30 mm Forstner bit to drill a 13 mm deep counter bore hole in the posts. Then you use a 13 mm wood bit centered in the hole to drill through into the center of the mortise for the back rail's tenons.

**Important:** For the front posts, it is not possible to drill the 30 mm counter-bored holes. There you only drill the 13 mm hole through the posts. The position of the hole is also different than on the back posts (see the plans).



13 mm holes are also drilled in the two short upper rails (upon which the two bench tops lie). These holes will eventually be used to screw the bench top down onto the frame.



In the next step, the front left post will be machined to allow the installation of the Crisscross Parallel guide. When using the router to cut the groove, a second parallel fence, and stop blocks, should be used here as well to guide the cut and prevent the router from getting pulled or drifting out of line. It is important to set the router so that the 16 mm straight cutter takes a maximum of 5 mm with each pass, until the design depth of 36.5 mm in the groove is reached. The ends of the groove are then squared off by hand with a mortise chisel.



The Crisscross-Parallel guide "Solo" model is, practically speaking, really only possible to install when building a new bench. With this model, you must drill an absolutely straight and true 9.5 mm hole through the 130 mm thick front post (leg of the frame). This can only be done reliably with a high-quality drill press. If you want to use a normal 9.5 mm metal bit to drill this hole, then you should carefully mark the position of the hole across the front of the workpiece.

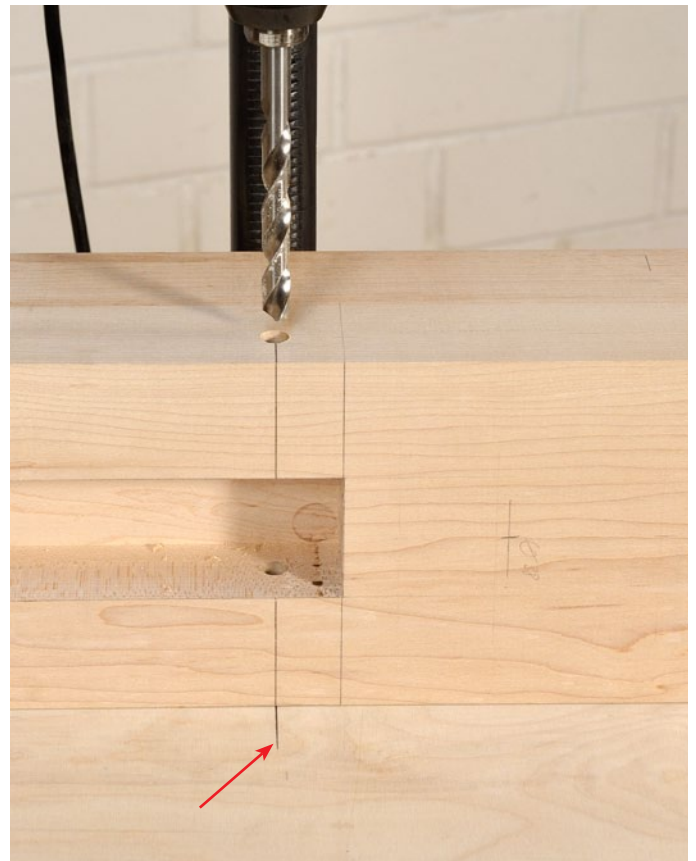

You then mark the position with a pencil on the table (red arrow) and bore the hole just into the cut-out. You then turn the post over and position it exactly onto the mark on the drill press table. (photo above) In this way you can be sure that the hole will be straight and true. Before drilling this hole, you must make sure the drill press is exactly at a 90° angle to the table in both axis, and that the post is securely held in place during drilling.



If you choose to install the “Retro” model of the Crisscross-Parallel guide, you must route out the long groove demonstrated on page 12 (the dimensions are identical for both models!). But for the Retro model, there is an extra, wider, rectangular section at the top that must be cut out. This is easily done with the router, again using two parallel guides. It is a bad idea to try to cut this groove completely by hand as the bottom of the groove must be exactly parallel to the face of the post along its entire length. If this is not done right, the Crisscross mechanism cannot seat properly and will not be able to run freely and effortlessly as designed. But the corners and ends of the groove can be cut by hand with a chisel with no problems.

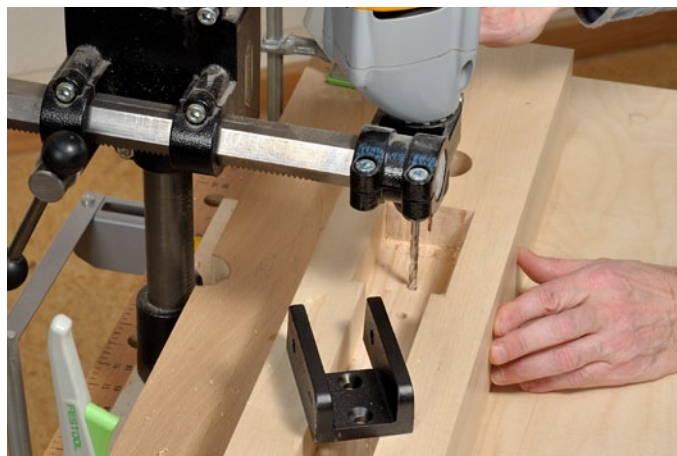

In contrast to the Solo Crisscross, with the Retro model, the pivot for the top of the mechanism is attached to the leg using a massive cast iron bracket. It is installed into the leg butting against the top of the groove (with the two screw holes oriented toward the bottom of the rectangular cut-out). Then the locations for the two screw holes are traced and drilled out with a 6 mm bit.



To finish the holes, you insert a 5/16-18 inch thread tap in a hand drill at very slow speed in the first pass, cut the threads in the 6 mm hole. Be very careful to hold the drill as straight as possible, and slower is better when cutting threads for machine screws in wood like this. Use no pressure, the weight of the drill will be plenty to get the job done. When the tap reaches the bottom of the hole, put the drill in reverse and back the tap out of the hole slowly, taking care to keep it straight.

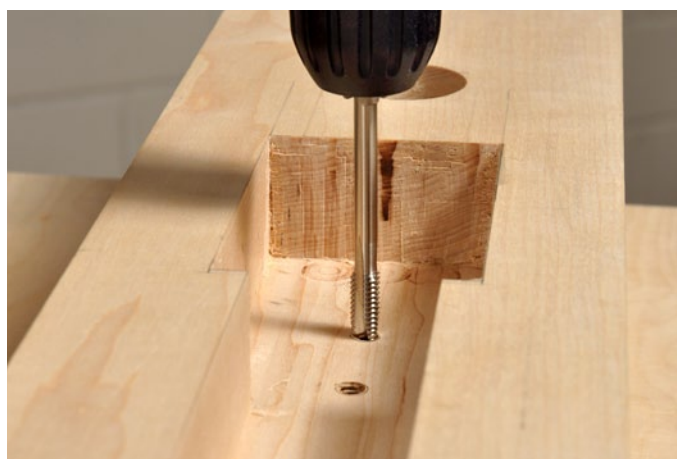

All this sounds much more complicated than it actually is when you do it. I found that the cordless drill gave me better results, on the first try, than I could get using the traditional hand wrench with the tap. It is a very good idea to try this operation several times on off-cuts from the same wood you are using for the bench to get a good feel for the method. I am sure you will be just as excited as I was with the results, especially the extreme strength of the method. I really did not expect it to work so well, and the strength is higher than you could find with any normal wood screw in the same length. Important: never try to recut the threads, this will greatly reduce the holding power of the threads.

## WISE SCREW HOLE AND NUT



For the hole to take the vise screw, you use a Forstner bit to drill, 54 mm from the end of the slot, a 38 mm hole all the way through the post. Because the hole must be 90 mm deep, we advise you to use a forstner bit designed to take an extension shaft. That way the hole can be drilled straight through the post in one operation (don't forget a piece of scrap wood underneath for a clean exit hole!) To complete the hole, you accurately mark off the piece, and then re-work the hole by drilling in again, from each side to the middle of the post.



The nut for the acme-thread vise screw is also installed with machine screws to the back of the post. To do this, you first mark off the positions of the four screws precisely in relation to the middle of the hole for the vise screw, and then drill the marked holes with a smaller, 4,5 mm bit. Finally you use the same method, with a 1/4-20 inch tap and the cordless drill to cut the threads for the round head machine screws.



Lay the acme-threaded vise nut in place and screw it down with the machine screws provided. To do this you will need an Allen key or wrench in 5/32". You will again surely be surprised by how solidly this method fixes the nut in place.

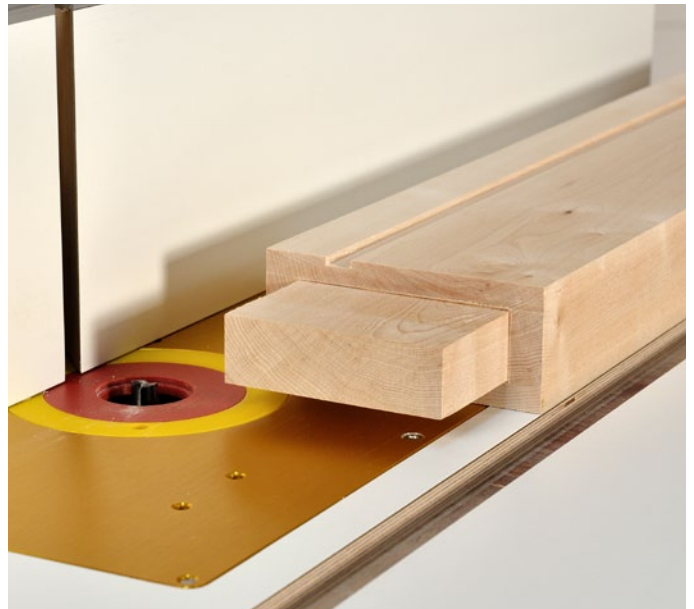

Before glue up, you must cut a 10 mm wide and 3 mm deep groove in all four bottom rails. Later, you will glue strips of wood into the grooves to support the three plywood panels that are laid in place loose to form the bottom shelf.

## GLUING UP THE SIDES OF THE FRAME



Once you have completed all the necessary holes and grooves, you can now glue up a post with the top and bottom side rails. Carefully check with a square that the rails join the post at an exact 90° angle. Let the glue dry for at least two hours, before you glue up the second post. During this step, you must again check that everything is exactly square. Even though this two-step method takes a little longer, never try to glue up the frame in one step, especially if you are working alone!



After letting the glue cure completely, overnight at least, you can then peg the joints from the outside using two, contrasting colored, 10 mm walnut dowels. To do this you use a portable drill stand and drill two 50 mm-deep holes into each of the joints.



Finally, put a little glue in each hole and drive the dowels home. This step adds a nice decorative touch to the joints, but it is also structurally very important. The pegs add a great deal of strength to these joints, and this is especially important for something like the frame of a workbench, which must withstand very high stresses during its long life.

## JOINING THE LONG RAILS TO THE SIDE FRAMES



To attach the long rails to the side frames, you use a bed bolt through each joint. A hole is drilled into the rail to insert the round barrel nuts. The nuts have a diameter of exactly 25 mm. If you use a bit with a diameter of 1 inch (25,4 mm) this gives you the perfect amount of “play” to make installation easier. But it also works with a 25 mm Forstner bit, if you move the bit in and out of the hole a few times to create more clearance for the barrel nut.



You can drill the holes for the 127 mm-long bolts, which will later be screwed into the nuts, even after the sides of the frame have been glued up. For this the frames must be supported from underneath on the outside to keep everything flat and square to the drill stand (Use a square!). Be sure to remember that the position of the holes in the front posts are somewhat different from the positions in the rear posts. Check and re-check these positions! It is not necessary to counter bore for the bolt heads in the posts. Counter boring for the heads makes them look nicer, but does not add any strength.

The next step is to provisionally assemble the rail in the mortise, make sure everything is straight and square (use a square!), and clamp everything solidly in place. Then you put a long, 13 mm auger bit in a hand drill and insert it into the 13 mm hole you previously bored in the post. Hold the drill in both hands as straight as possible, and drill the hole slowly (!!!) until you reach the hole for the round nut in the rail. If everything goes well, you will hit the hole right in the middle. If not, you take the rail out of the post, and use a normal wood bit to widen the long hole enough to allow the bolt to properly thread into the barrel nut.



## DOVETAIL JOINTS FOR THE BENCHTOP



The front half of the benchtop has a 40 mm-thick front board, which is joined to the endgrain of the right front end of the top using half-blind dovetails. You can naturally cut the dovetails by hand, or, as you will see here, use a “trimming” table saw. The advantage of this method is that you can build a jig and clamp the workpiece in position on the saw’s table. Then it is just a matter of pulling the saw blade through the wood.



Because you do not need to move the workpiece, you can safely work even long and narrow boards on this kind of saw. Do not try this, under any circumstances on a normal table saw, because it is too easy for the workpiece to tip and dangerously foul the blade!!!! If there is not enough room between your table top and the ceiling of your workshop to clamp this board on its end, then you can take the saw outdoors to work for this joint. The saw blade is set at an angle of 8° for all the cuts.



To make the jig for this job, you simply screw two 18 mm pieces of ply or particle board to the proper angle. At the corners you screw two right-angled pieces to reinforce the jig, (they don’t have to be cut at an angle as in the photo, it just looks nicer). This jig is then clamped exactly at 90° to the saw blade and then clamped to the table top with two lever clamps as shown. The wide board on the face of the jig provides a stable surface, at a precise 90° angle to the table top to clamp the narrow workpiece against, also using two clamps.

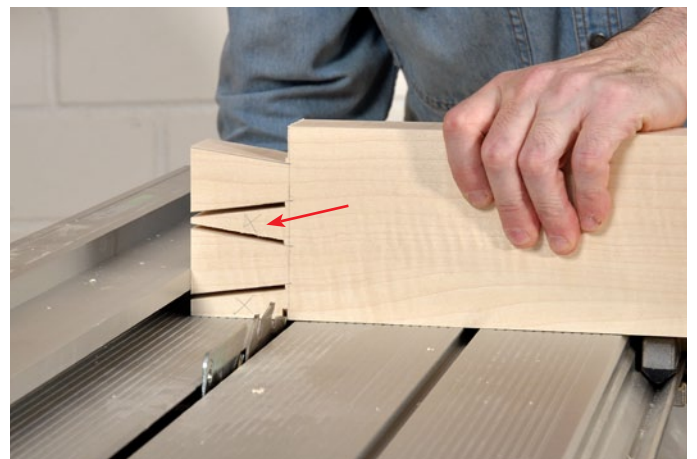

When you have finished all the angled cuts, then cut off the two outside waste pieces on the trimming saw, using the miter and length attachments. The middle waste piece (arrow) should be cut out with a chisel, working from the ends to the middle. I recommend that the front board be cut about 10 - 15 cm too long (210-215 cm). Then you have a room to recut the dovetails a second or even third time if the first try is less than perfect.

## PINS IN THE ENDGRAIN (BENCHTOP)



The next step is to set the dovetails in the front board precisely in position against the end board (also a good idea to cut it a little long), clamp everything down flat and square, and then trace the pins out on the endgrain. In this step, even a tenth of a millimeter counts! So it is a must to use a perfectly sharpened pencil, or a sharp marking knife. Then you transfer the lines with a square to the inside face of the board.



In this step you need to carefully position the workpiece against a jig, so that your 8 mm spiral cutter router bit cuts very precisely within the lines you traced for the pins. To do this you need to clamp a piece of high quality, straight plywood about 20 cm high, 40 cm long (at least 24 mm thick) to the miter gauge of the router table. The miter gauge is set to the 8° angle. To make sure that nothing can move or slip when cutting, clamp stop boards tight against each side of the workpiece.

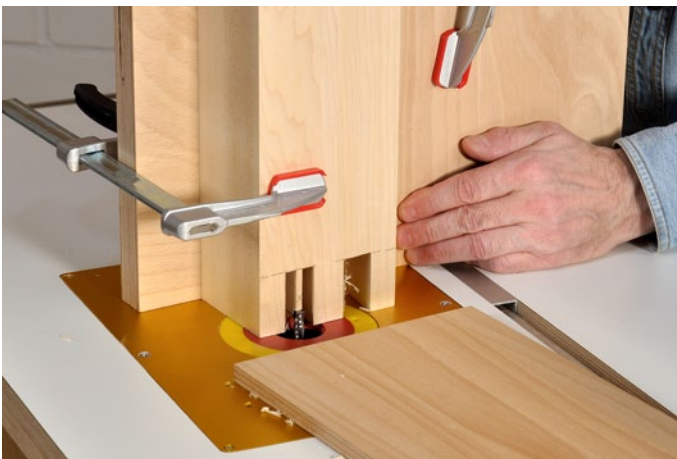

The 40 mm-high cut outs must be made in several passes, with a maximum of 5 - 7 mm with each pass. To make sure you do not cut too far, it is important to clamp another stop board to the router table top. It is best to stay a hair's width away from your layout lines. It would be more than frustrating to later discover a gap in the joint. Remember that it is not a problem to pare back the joint to the lines, but you can't invisibly put wood back in after it has been cut out.



The last, fine fitting of the dovetail joint is best made by hand with a very finely sharpened paring chisel or two. Finally, press the two pieces of wood together without glue to check how closely fit the joint is. The fit should never be too tight, because of the risk of splitting the board along the end grain. When the fit is perfect, the joint will go together with light taps.

## TENONS FOR THE END BOARD ON THE FRONT BENCHTOP



On the right end of the front benchtop you must cut a tenon 40 mm thick and 32 mm long. This is best done with a heavy router and a guide rail using as large a bit as possible - 35 mm works well. Be careful that the router stays in good contact with the rail, and that it does not tip one way or the other. Because you must cut a rabbet of...

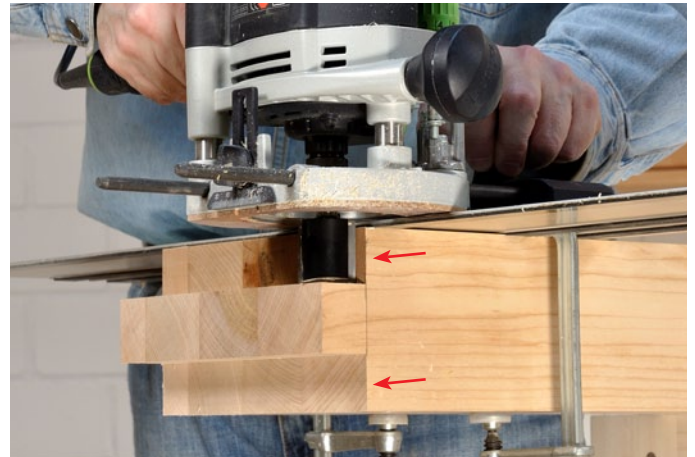

... 32 x 32 mm from each side of the benchtop to get the 40 mm tenons, it is extremely important that the guide rail is clamped exactly square and in the same plane. Only then can the two shoulders of the tenons (arrow) be also exactly in the same plane.

## ROUTING OUT THE RABBETS FOR THE GUIDE RAILS OF THE TAIL VISE



The guide rails for the tail, or wagon, vise need to be installed in rabbets on the underside of the benchtop, and the next step is to cut them out using a router with a big straight cutter. First mark out the areas to be worked (59 mm wide and 360 mm long). Clamp on the front board with the dovetails (no glue at this point!) using heavy clamps. At the edge of the bench, where there is a gap between the dovetails and the tenon, clamp a scrap of wood under the tenon to bear upon the dovetails to maintain the gap. Now you can use another clamp to secure the front board to the rest of the benchtop at the dovetailed end.



Then use a router with a big straight cutter and the previous setup of two parallel fences to gradually cut out, the rabbets to a depth of 52 mm. You can see now why it is important to clamp the front board, although it is 40 mm thick, with a temporary board. This is another instance where you need to make many shallow passes, cutting a maximum of 5 mm deep each time. This protects the router, and especially the expensive router bit.

## CUTTING MORTISE IN END BOARD AND DRILLING VISE SCREW HOLE



This is how the finished rabbets for the wagon vise should look. In this photo you can again easily see the temporary strip of wood clamped to stabilize the front board at the dovetailed end while you were routing out the area for the wagon vise mechanism. Now you unclamp the front board, and cut the waste from the big tenon, (outlined in red) using a hand saw.

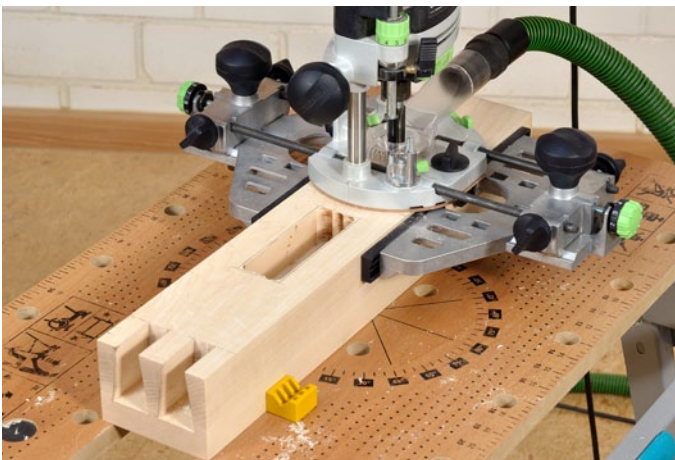

The mortise to take the tenon on the end of the benchtop is cut using a router and a 16 mm straight cutter. Here again you use two parallel fences on the router to keep the cut accurate. In this step you should first leave a little wood inside your layout lines, and then test the fit, cut, and retest the fit of the mortise on the tenon. Here also, the fit is optimal when you need only very light taps with your hand to drive the joint closed.



The two holes for the bed bolts to join the end board are drilled with a 9,5 mm drill bit. The back hole is then slightly enlarged to an oval shape with a rat-tail file to allow enough room for the bench to “work,” to swell and shrink with changes in humidity.

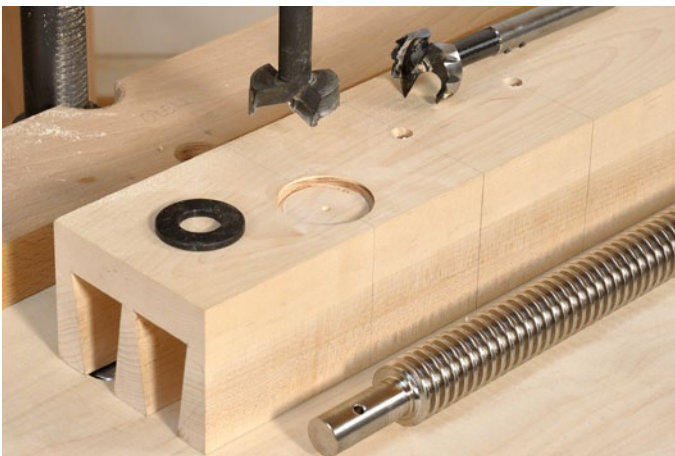

For the vise screw hole, you first use a 45 mm Forstner bit to cut a counter bored hole (maximum of 5 mm deep) that will later take the washer. Then you use a 38 mm Forstner bit to drill the hole for the vise screw all the way through the board.

## END BOARD INSTALLATION AND FRONTBOARD GLUE-UP



To install the long round barrel nuts, (red arrows) drill two 22 mm diameter and 70 mm deep holes in the underside of the benchtop. Then test to make sure the bolts mate properly with the round nuts. If needed, you can slightly enlarge the bolt holes in the tenon. Once the bolts are fitted and everything is clamped precisely in position, you can also test install the tail vise mechanism to make sure everything is right, that the areas routed out are properly dimensioned and that the threaded plate has enough space on all sides to move freely along the length of the screw.



To eliminate the possibility that the front board could slip out of position during glue up, it is a very good idea to install a couple of size 10 biscuits into the joint to keep everything lined up properly. This makes glue-up go easier and faster, and can save a lot of time and touch-up work on the benchtop later. Before applying the glue, it is absolutely necessary to make a dry fitting without glue. Then when everything is properly fit and lined up, lay out everything you will need to glue up the front and side boards close to hand, and if possible ask a second person to help you.



In order that the heavy clamps do not bear directly on the newly planed surfaces, you should plan on two other boards to be used as clamping pads both above and below during the glue-up. I did not bother to put any glue on the dovetail joint, because there was no play at all. But to keep the joint from moving over time, I drilled a 10 mm hole from the underneath (see next page) and pegged the joint together. Of course the dovetail joint can also be glued. Again, after glue-up the top should be left overnight for the glue to cure properly.

## MARKING OUT AND CUTTING RABBETS FOR GUIDE RAILS (TAIL VISE)



To stabilize the dovetail joint, drill a 10 mm hole 90 mm deep through the exact middle of the joint from the underside of the benchtop. Pour a little glue into the hole and drive a 10 mm grooved dowel into the hole.



Lay the two guide rails with the sliding threaded plate on the underside of the bench, and mark off their position on the wood with a sharp pencil. Do not leave any space between the rails and the sliding plate!



Next route out, using the parallel guide fence and a 16 mm straight cutter bit, the front groove, or rabbet, which is 19 mm wide and 6 mm deep in the underside of the benchtop. So that the router stays flat and level to the bottom of the benchtop and doesn't tip into the cut-out, attach a level-guide adapter to the router (red arrow). This attachment rides at exactly the level of the bottom of the router. If your router does not have this kind of adapter, you can make one fairly simply out of plywood, or simply clamp a strip of wood of the proper thickness for the parallel guide bars to ride on.



To route out the second groove, stick the adapter on the other side of the router (red arrow), so that it will ride solidly on the front board of the benchtop. In this way the machine cannot tip and you can cut the second 19x6 mm groove in under the benchtop. Then lay the two guide rails and the sliding plate in the grooves and check how easily the sliding plate can move. The plate should move freely but without play in between the two rails - about a half a millimeter of air on each side. If the plate binds at all, then use the fine adjustment on the parallel fence and take another very thin pass with the router to slightly widen the inside rabbet.

## MOUNTING THE DIAMOND-SHAPED FLANGE



Finally, screw the guide rails in place in the rabbets with the screws included in the kit. With hardwoods, especially the hard maple in this example, pre-drilling pilot holes is an absolute must.



Screw the vise screw into the threaded plate and lay the big washer in its 45 mm hole. Finally, place the diamond-shaped flange over the end of the vise screw. The spindle and washer will have some play in their fit so that you can line up the vise screw to run exactly parallel to the guide rails. This is very important to allow the vise to glide evenly along the entire length of the rails. If the vise screw is not well-aligned, the sliding plate will not be able to move along the entire length of the rails, but will tend to hang up somewhere.



Be careful to make sure the end of the diamond on the left side is positioned so it is tilted somewhat up (see photo). The left hole then is closer to the middle of the end plate and the right one near the bottom. This means that the two holes will be free in the area you routed out for the vise mechanism, and you can then easily slip the U-washer and nuts over the ends of the bolts and tighten them down. The 8 mm holes you need for the bolts are best drilled in the end plate using a portable drill stand.

Even though the type of drill stand shown here is not very precise, it works just fine for this kind of job. In any case, it is better to use such a stand than to try to bore the holes free-hand.

## ROUTING THE MORTISES FOR THE POSTS UNDER THE BENCHTOP

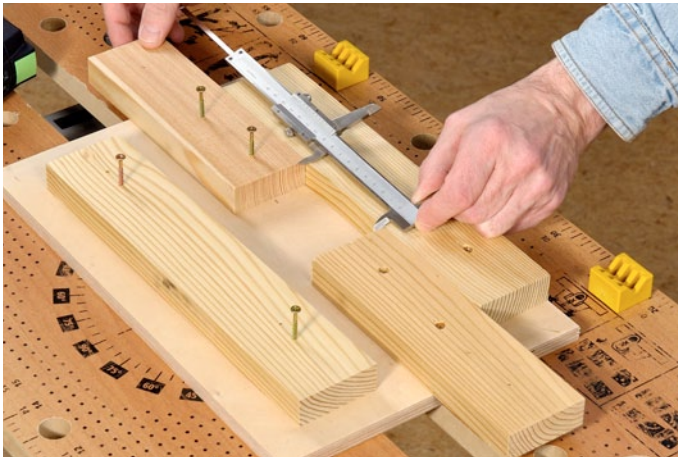

To locate the posts' end tenons precisely in the underside of the benchtop, you should again use the router with a 16 mm straight cutter in combination with a pattern or template to guide the cut. The dimensions of the tenons are exactly 80 x 45 mm. If you use a 30 mm guide bushing together with a 16mm straight cutter in a template, (30 - 16 = 14 mm offset), you will need a pattern cut out to exactly (80 + 14) x (45 + 14), so 94 x 59 mm. To make the template, first you plane a couple of thin boards to exactly 59 mm wide, and screw them down to the template so that you have a space exactly 94 x 59 mm (photo above).

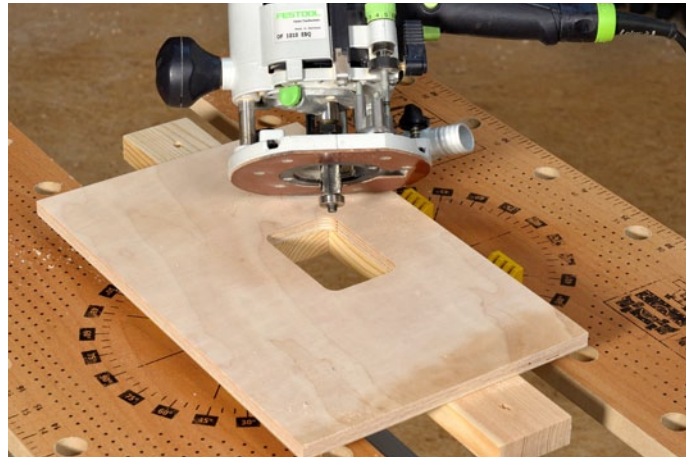

Then you rough cut the middle part with a jigsaw and then use a router with a trimming cutter to trim the cutout portion exactly to size. In this step the ring bearing runs on the boards you screwed down to the plywood. You cannot find a quicker, simpler, and more precise way to make this kind of shop tool.

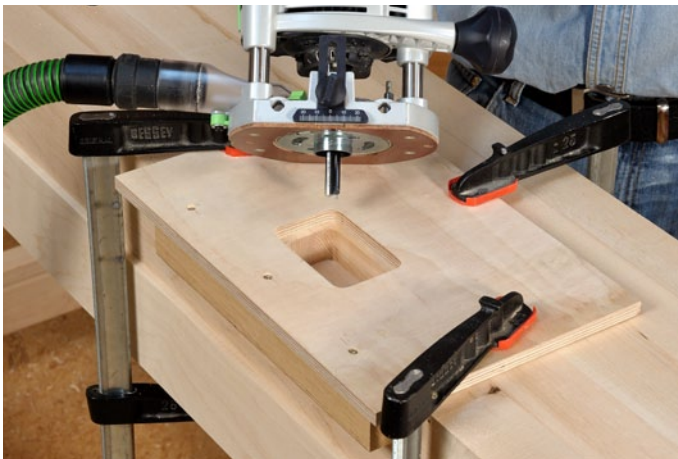

In order that the template always sits in the same position, screw down another lath underneath to act as a stop. Then you carefully draw the positions for the mortises on the undersides of the benchtops, carefully place your template on the wood, and use the router with the 30 mm guide bushing and the 16 mm straight cutter to cut the mortises 27 mm deep. The rounded corners can then be squared off with a mortise chisel. Finally, you put the two benchtops on the posts' tenons and then screw the tops down with four 9,5 x 127 mm wafer head screws (Attention: Torx 50!!!). In this step, you absolutely must drill pilot holes and use a little grease on the screws!



First, a 19 mm hole is drilled into the moving head for the wagon vise to take a bench dog. After that you saw, in the back underside of the head a 51 mm high and 25 mm wide notch for the threaded vise plate. Then the head is screwed to the plate with the screws provided for this (also in this piece, drill pilot holes for the screws) Important: The wooden head must be just slightly thinner than the slot so that it can glide easily.



## MORTISE FOR THE PLASTIC BUSHING FOR THE LEG VISE SCREW



The chop for the tail vise should be cut about a millimeter longer than necessary so that it can be planed back later to precisely level with the bench top.



The vise screw for the leg vise is guided both by the nut at the back of the post, and a plastic plate bushing set into the face of the post. This square plate is centered directly over the hole in the post for the vise screw. To do this job it is also best to use a template and a router with the 30 mm guide bushing and the 16 mm straight cutter. The design depth for the plate's mortise is 12.7 mm, but it is fine to cut it to 13 mm because in no case can the plate stick out from the face of the post. You need to allow about 2 mm of space all around the plastic plate.



The hole in the plastic bushing is slightly oval and the plate should be installed so that the long dimension of the oval is perpendicular or up-and-down in the mortise. The screw then has a little space to move up and down, making the vise easier to move. Horizontally - left to right- the screw fits perfectly in the plate, reducing greatly any side-to-side movement.



The bushing is installed with the machine screws provided, and so you must here also drill and tap into the wood. Because there is a couple of millimeters space around the plastic plate, you can later adjust it slightly for perfect alignment with the vise screw.

## ROUTING THE SLOT FOR THE CRISSCROSS IN THE VISE CHOP



The vise chop is 130 mm wide at the bottom and 240 mm wide at the top. If you - to save a little wood - plan to get to the 240 mm width at the top by gluing short boards on each side, then you cannot use the double parallel fence method used elsewhere on the bench. In this case it is best to use a template here too, and then route out the groove using a straight cutter and a guide bushing. A clamp at the base of the board would interfere with the router, so the best way is to screw, left and right, laths that touch the sides of the board at the narrow end.



Now you can use a clamp to clamp those extra boards to the sides, and then clamp the top of the template normally (see photo). This method solidly fixes the template to the workpiece, and you can take your time and cut the groove for the Crisscross guide using many shallow passes with the router. If you choose to use one piece of wood 240 mm wide for the chop, then you do not have to make the template, and can simply route the groove using the double parallel guide set up. (look at pg. 12 for this).

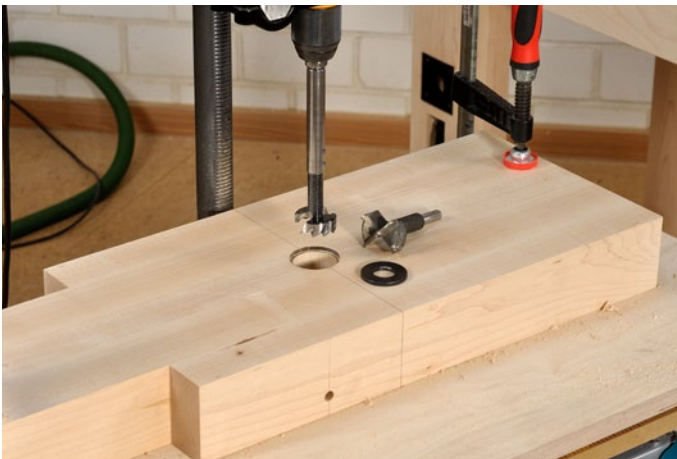

For the vise screw hole in the board, drill first a hole with a 45 mm Forstner bit a maximum of 5 mm deep to take the round washer. Then you drill a 38 mm hole through the chop for the vise screw.



The diamond-shaped flange here will be mounted exactly level and centered over the vise screw hole. Mark, drill and tap the threads in the holes in the chop board for the two 5/16-18 x 1-1/2 machine screws.



With the Crisscross-Parallel guide, model "Solo," the arms will be fixed to the post and the vise chop with a 9,5 mm diameter steel rod. This type of parallel guide is less expensive than the "Retro" model, but can only be recommended to those who have, or have access to the proper machinery to drill in the chop board, a perfectly straight 9,5 mm hole through the width of the 240 mm-wide vise chop so that the rod can be driven in. If you don't have a big, high quality drill press, then the "Retro" model of the Crisscross will work just as well.



Install the two arms of the Crisscross on the post and the vise chop, and then turn the vise screw a little ways into the post. Install the diamond shaped flange on the vise chop and the end of the vise screw. Bring the two arms of the Crisscross together in the middle so that you can push the short axel pin (with the spring retaining ring) through the holes. Before you stick the second retaining ring to secure the axel, you should first install the hand wheel on the end of the vise screw, and test the vise assembly.



If everything works smoothly and easily, close the chop completely. Then mark both the top of the bench, and the width of the post on the back of the chop (see photos above). Then remove the chop and saw it to its finished dimensions and desired form. On the internet, you can find a wide variety of shapes for leg vise chops. They range from simple, and purely functional, to any number of lovely decorative patterns. Let yourself be inspired by the choices, or you can just follow the dimensions we give in the building plan.

## DRILLING BENCHDOG HOLES AND BUILDING THE SLIDING DEADMAN



The original building plan, which was developed by Benchcrafted, called for square benchdog holes. We however have opted for standard 19 mm round holes and round brass dogs. Much more versatile, the round holes can also be used to accept a wide variety of other options for clamping workpieces and tools to the benchtop. These holes are easily and accurately bored with a drill stand. To do this, you turn the column 180°, away from the stand's table, which is clamped to the benchtop using the slot between the two tops. If you clamp a straight board to the top at the proper distance from the front edge, you can then drill a very straight and accurate line of dog holes.

If the drill bit extension is not long enough to drill all the way through the benchtop, you can use the simple portable drill stand to finish the last bit at the bottom of the holes. It is important in either case to clamp scraps of wood under the benchtop where the bit will exit so that the bit does not tear out the wood as it emerges.



The sliding deadman runs on a triangular track glued to the bottom front rail, which allows it to be slid back and forth between the two posts. At the top a tenon runs in a 16 mm wide and 36 mm deep slot in the underside of the front board of the benchtop. The triangular track can be fixed to the rail using a few screws, or as we will show here, can be glued down.

The bottom end of the deadman has a triangular channel cut along it to fit over the track. This channel can also be cut safely and precisely using a "trimming saw." To do this, you mark out the triangular channel on the bottom of the sides of the board, set the saw to 45° and clamp the board to the rip fence on the saw's table. Adjust the fence and the saw blade height to exactly match the marks, and saw the channel with two cuts (turning the board around for the second cut) to remove a triangular section out of the bottom edge of the deadman.

This diagram shows the dimensions of the track in cross-section. Total length (1055 mm).

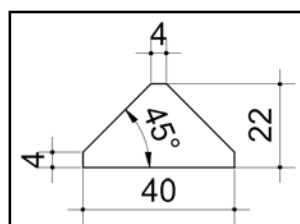



At the top edge, a rabbet is cut in the deadman to create a long tenon to slide in the 16 mm slot in the underside of the benchtop front. The tenon is cut back, or relieved slightly at its base using a rabbet plane...



... so that it easily can be slid at an angle into the guide slot in the benchtop, but you should be careful to leave 10 - 12 mm at the top untouched so that there is not too much play between the tenon and the slot when you use the deadman.



The bottom edge of the deadman sits on the triangular track. The face of the deadman should be flush with, or sit just a little back from, the rail and the front edge of the benchtop.

Next you mark out and drill the 19 mm holes in the deadman using a drill stand. Then the contours in the edges of the deadman are cut.

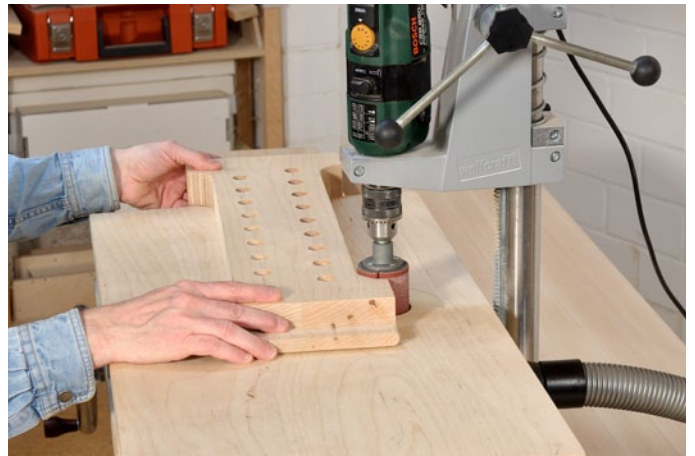

The saw marks can then be cleaned up using a sanding drum in the drill press.

## BUILDING THE BOTTOM SHELF AND PLANE OR BENCH HOOK BOARD



First, cut a rabbet in a batten, 25 mm high and 18 mm thick so that you leave a rectangular section that precisely fits the groove that was routed into the long rails. (see diagram). The battens are also notched underneath to allow clearance for the round nuts for the bed bolts joining the rails to the posts. Then spread a coat of glue and use as many clamps as you have to clamp the battens in the grooves.

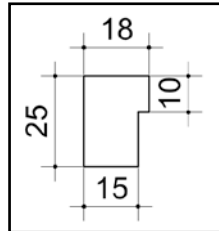

The shelf is made out of three stable pieces of 18 mm birch multiplex plywood. They are half-lapped at the joints between the pieces. The two outside pieces are also notched to clear the posts. They are just set in place to allow removal if needed.



The plane or bench hook board is made of three layers glued together. The two outer strips run the length of the board, and the middle layer is made up of short pieces of wood. In use, you can temporarily store a variety of different kinds of tools in the slots formed. To help prevent the pieces from slipping out of place during glue-up, you will put, with the glue, two short screws to join the pieces to one of the long strips. When finished, the screws will not be visible, and really do a lot to make the glue-up much simpler.

I chose American Walnut to make the piece. I think the wood makes a lovely contrast to the very light maple wood. You can, naturally, use any other kind of wood that you would like.

Finally you brush some glue on the middle pieces, and lay the second long strip in place. Then the assembly is carefully clamped up and is best left overnight for the glue to set properly.

If you place the finished board in the slot between the two bench tops, it will stick about 15 mm above the top. To allow it to sit flush to the benchtop, set it into the slot even with the ends of the bench, and from underneath the bench, mark the position of the two upper side rails on the bottom of the board. Then you remove the board, and cut out notches, exactly 15 mm deep and the width of the rails. In this way, depending on which edge you insert into the bench, the board can stick up as a stop, or lie flush with the top.



### 1. Lubricating:

If you have installed everything correctly, the vise screw and the chop should move easily in and out without needing any kind of oil. But the the Benchcrafted vises will work even better with a light oiling. Commonly found light spray oils, like WD 40, work just fine, but the best choice is a spray based on PTFE - the non-stick material in Teflon coatings. Also spray a little into the hole in the diamond-shaped plate on the face of vise. This will help the end of the screw turn easier in the flange.

### 2. Clamping power:

In order to allow the leg vise to develop its optimal clamping power, the chop must be at least 70 mm thick. More than 80 mm does not help significantly, and of course adds weight to the chop. A second potential issue with the vise is that when it is closed against the benchtop, there should be a slight gap between the bottom end of the chop and the post (see arrow). If you turn the hand wheel another 1/4 turn, the gap will close slightly. This slight flexibility in the mechanism allows a consistent, and high, clamping pressure to be applied over the whole range of the vise's clamping width. This allows the vise to perform well, no matter how small, thin, or thick the workpiece might be.

If you cut the slot for the Crisscross exactly 36.5 mm deep along its entire length, the gap between the chop and the post should be perfect. If the slot is a little too deep, and there is a tiny gap or none at all, you can, with the "Retro" Crisscross, insert a small spacer under the two blocks joining the arms to the post and the chop.



The square plastic bushing stabilizes the lateral play in the vise screw. By moving it slightly left or right, you can minimize, slightly, any play. It is not possible to eliminate it all together, and with an acme screw like this a little movement is completely normal, and this does not hinder the function in any way.



Putting shims under the two metal plates the ends of the arms rest upon will also increase the gap at the bottom of the vise, and create more clamping power at the top of the vise. With the "Solo" Crisscross, this is the only way to tune the clamping area. With the "Retro" model, you should shim both at the top and the bottom of the arms.

## ALL THE IMPORTANT DIAGRAMS: THE BENCH FRAME

---

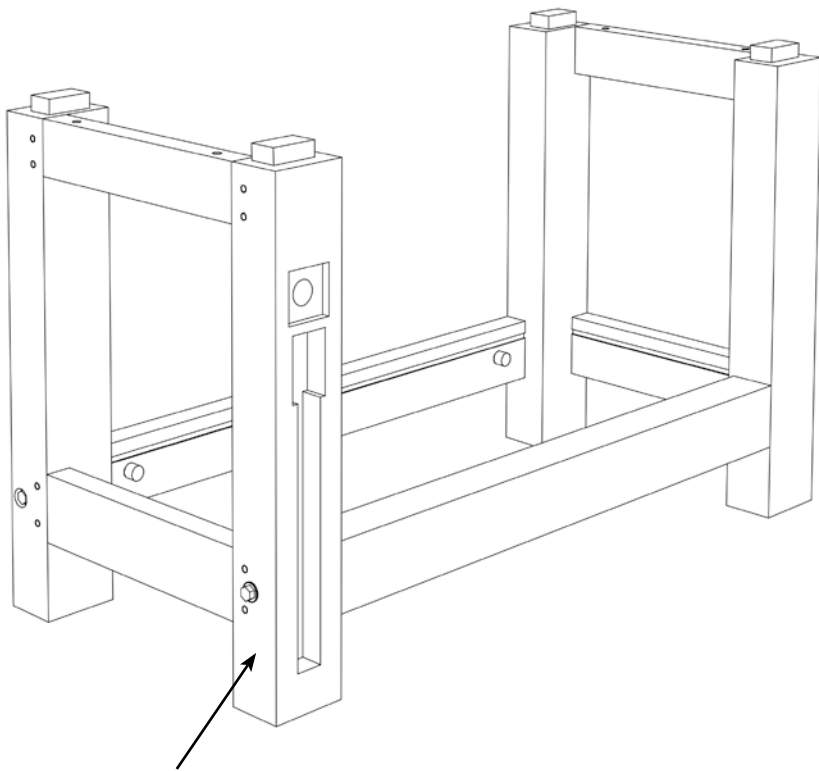

Post with slot for the "Retro"-  
Crisscross Parallel Guide

In the following pages, you will find a three-dimensional drawing for the back and front of every post with all the necessary dimensions. The two long rails and the short rails for the side frames are also drawn with the tenon dimensions. I deliberately did not compile a material or cut list, so that you do not blindly just start rough cutting all the parts out. With some parts, the face board and the end board or clamp, for instance, it is smart to cut them a little longer than their final dimensions, and then later, when the joints are well made, to cut them to their finished lengths.

On this topic, it is extremely important, before you start cutting and building, to carefully read and study the plans and instructions to familiarize yourself with every detail of the bench and building process.

Note that in February 2025 Benchcrafted released a new Crisscross which requires a shorter mortise in the leg and chop. Use dimensions below labeled "CCARMV2" if you are installing this updated Crisscross.

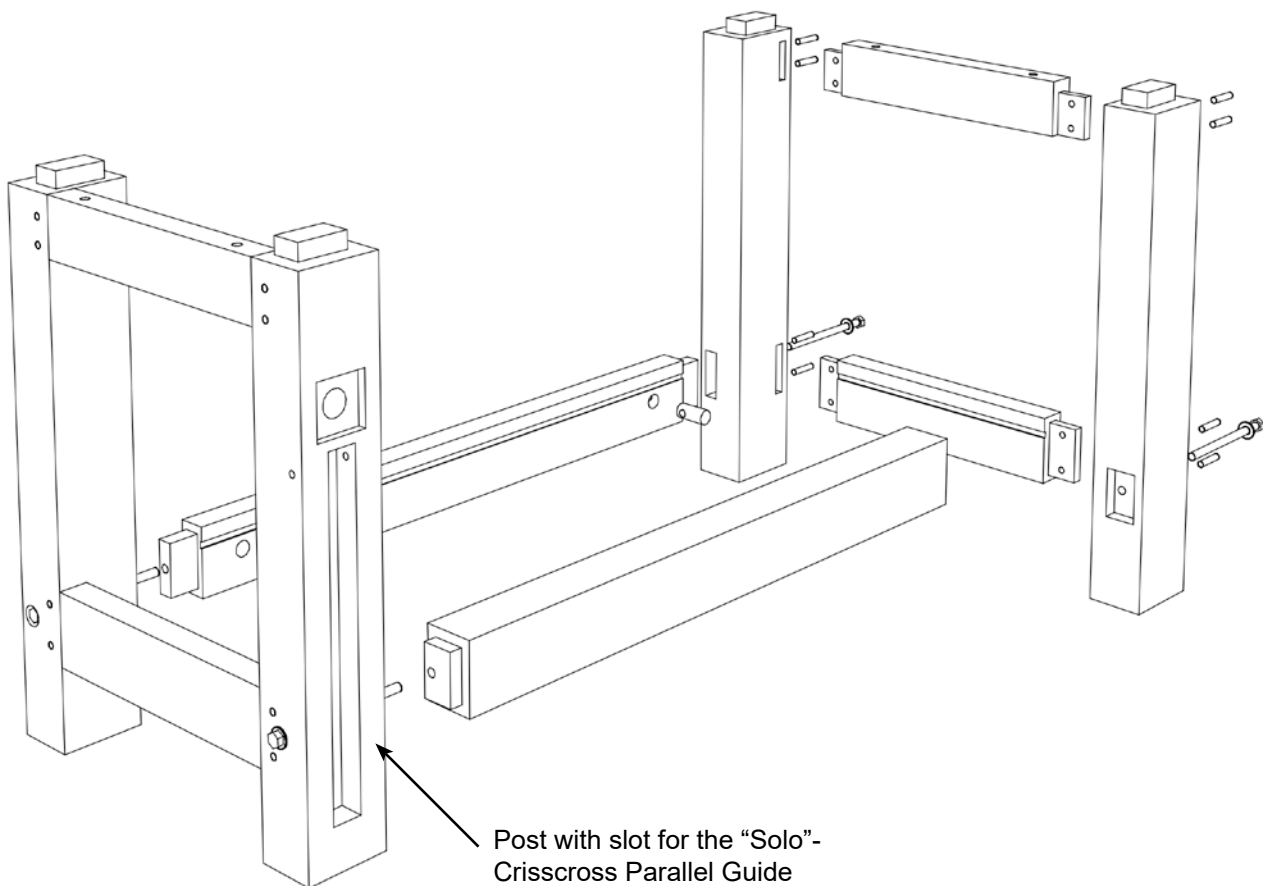

Post with slot for the "Solo"-  
Crisscross Parallel Guide



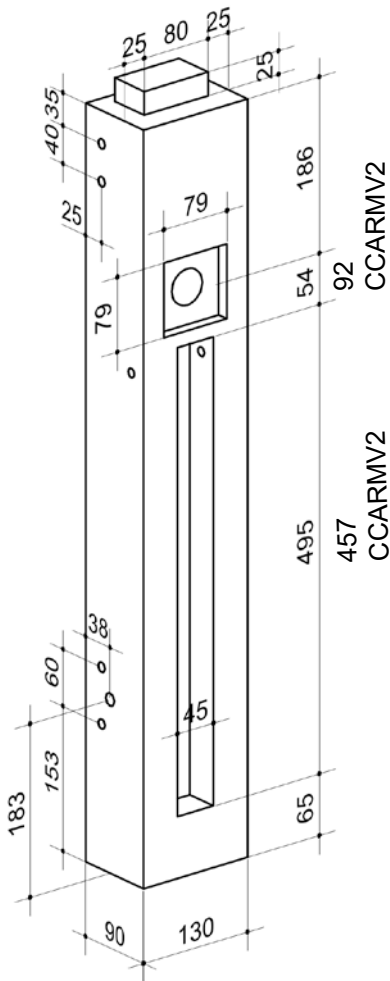

**Left front post**

Left front Post with slot dimensions for the Solo-Crisscross  
 Slot depth = 36,5 mm  
 Vise screw hole =  $\varnothing$  38 mm

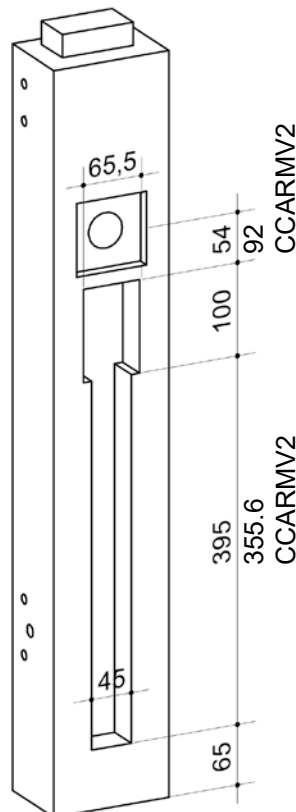

Left front post, with slot dimensions for the Retro-Crisscross parallel guide

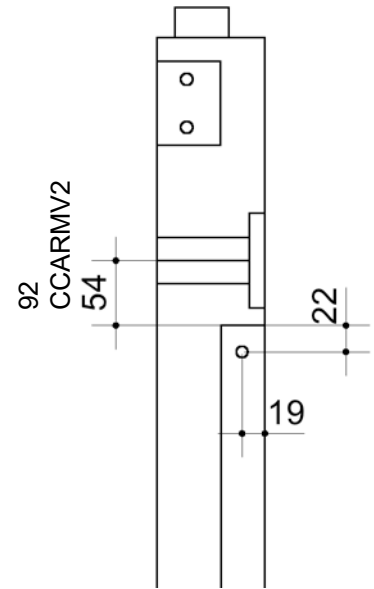

Hole diagram for the 9,5 mm hole to take the steel pivot rod for the Solo-Crisscross, the given dimensions are also used for the vise's chop.

A few especially important dimensions, that for reasons of clarity, are not found in the drawings:

1. The slot depth for both models of the Crisscross parallel guides is exactly 36,5 mm.
2. The mortise depth for the 16 mm wide tenons is 53 mm (always about 3 mm deeper than the length of the tenon).
3. The mortise depth for the big front rail is 23 mm (20 + 3).
4. The diameter of the hole for the vise screw is 38 mm.
5. The diameter of the holes for the bed bolts to join the long rails is 13 mm.

Many dimensions are also given in the text of the building instructions, which you must carefully read until you are familiar with every part and step.

# POST DIMENSIONS

For the right front post, here are some additional dimensions:

1. The mortise depth for the 16 mm wide tenons is 53 mm (always about 3 mm more than the length of the matching tenon).
2. The mortise depth for the big front rail is 23 mm (20 + 3).
3. The holes for the bed bolts to join the long rails is 13 mm.

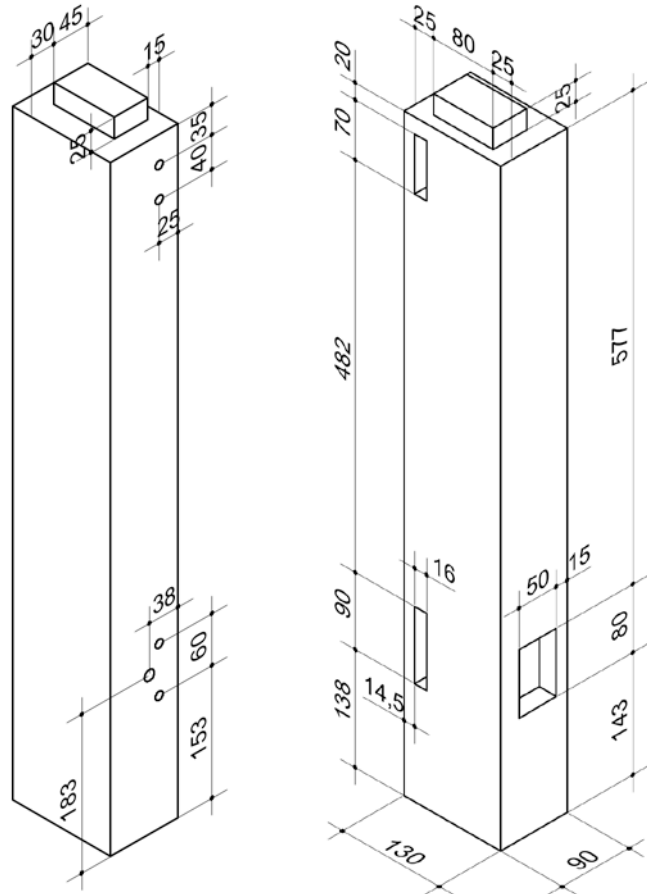

**Front right post**

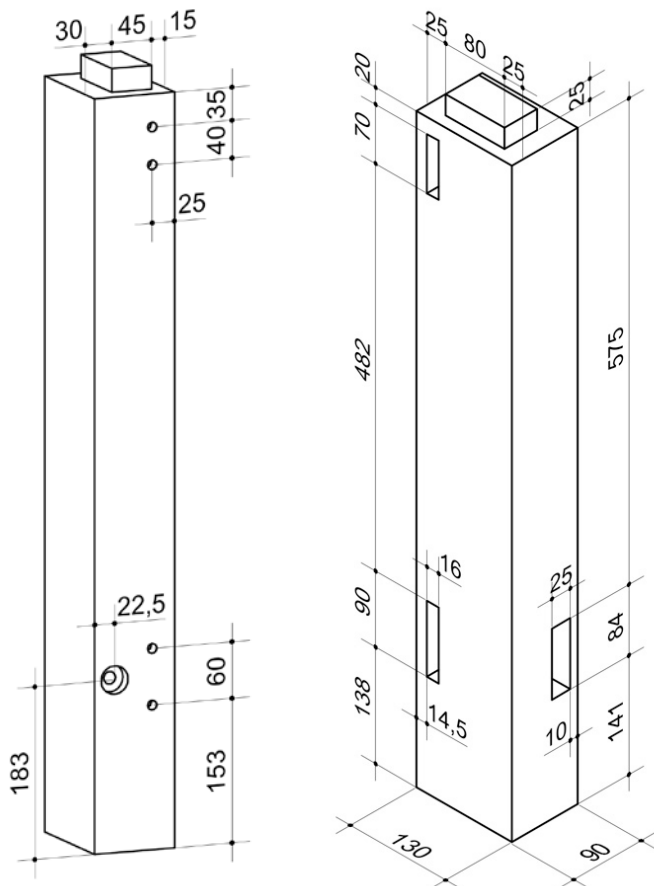

**Back left post**

1. For the back posts The mortise depth for the 16 mm wide tenons is 53 mm (always about 3 mm more than the length of the matching tenon).

2. Attention, the mortise depth for the narrow back long rail is also 53 mm (50 + 3).

3. The diameter of the holes for the bed bolts to join the long rails is 13 mm. If you would like to counter bore for the head of the bolts in the posts, (not necessary), then you will need to drill a first hole 30 mm x 13 mm deep. (see the text in the instructions).

## POST, LONG- AND SIDE- RAIL DIMENSIONS

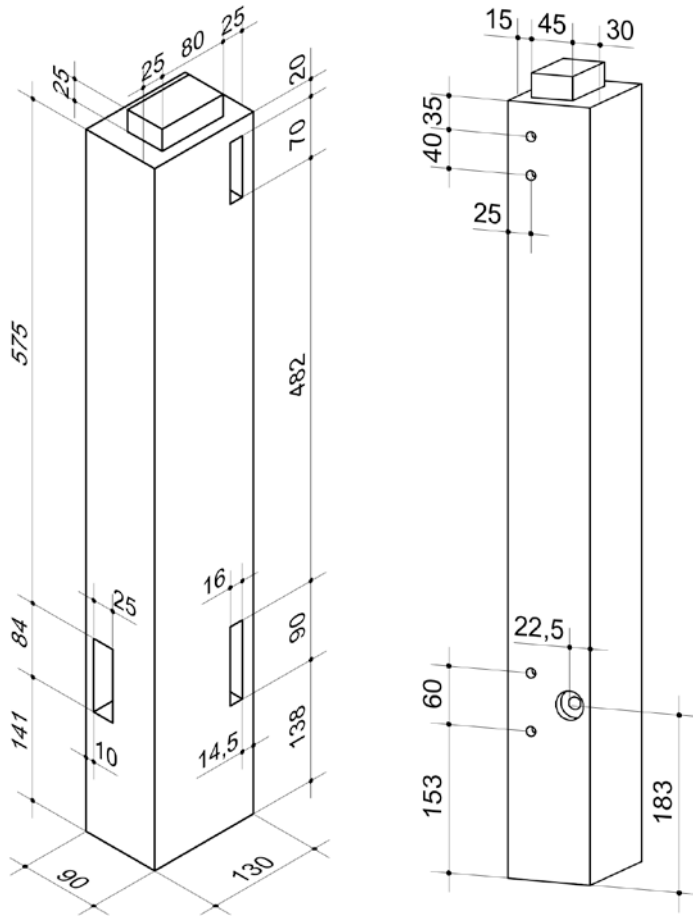

**Back right Post**

The mortise depths and hole diameters are the same dimensions as given above for the back left post.

### Important for all posts:

The upper tenons, which later will fit into the bench top, are not exactly in the middle of the end of the post. The tenons have, in relation to the outside of the post, a setback of 30 mm and on the inside only 15 mm. Left and right on the narrow sides of the posts, there is an offset of 25 mm, with both sides the same. When cutting the tenons in post tops, it is very easy to make a mistake. So take extra care with the layout, check and double check, standing the posts oriented like they will be in the bench together, and making sure the tenons are correct.

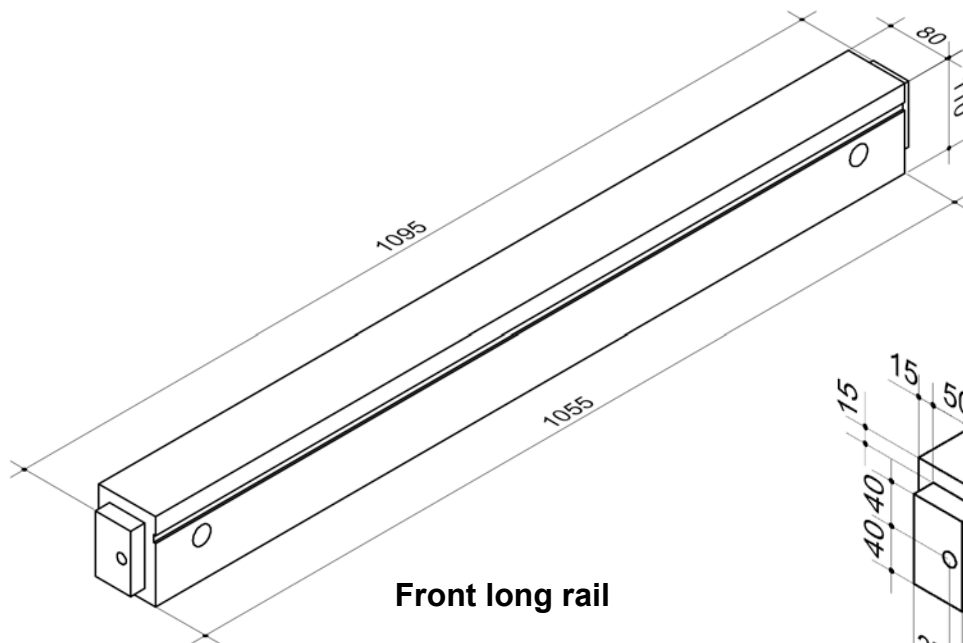

**Front long rail**

### Important advice!

The front long rail, at 80 mm, is much thicker than the narrower rear rail, which is 45 mm. You need a thickness of at least 77 mm for the bed bolt hole to clear the slot cut out for the Crisscross arms.

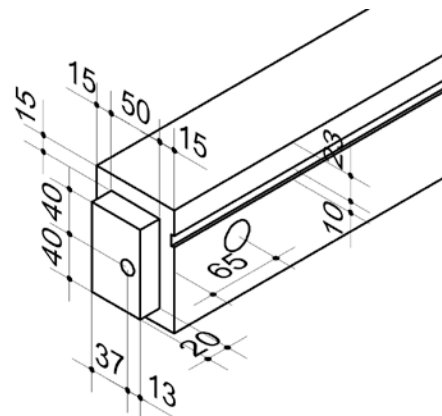

# LONG- AND SIDE- RAIL DIMENSIONS

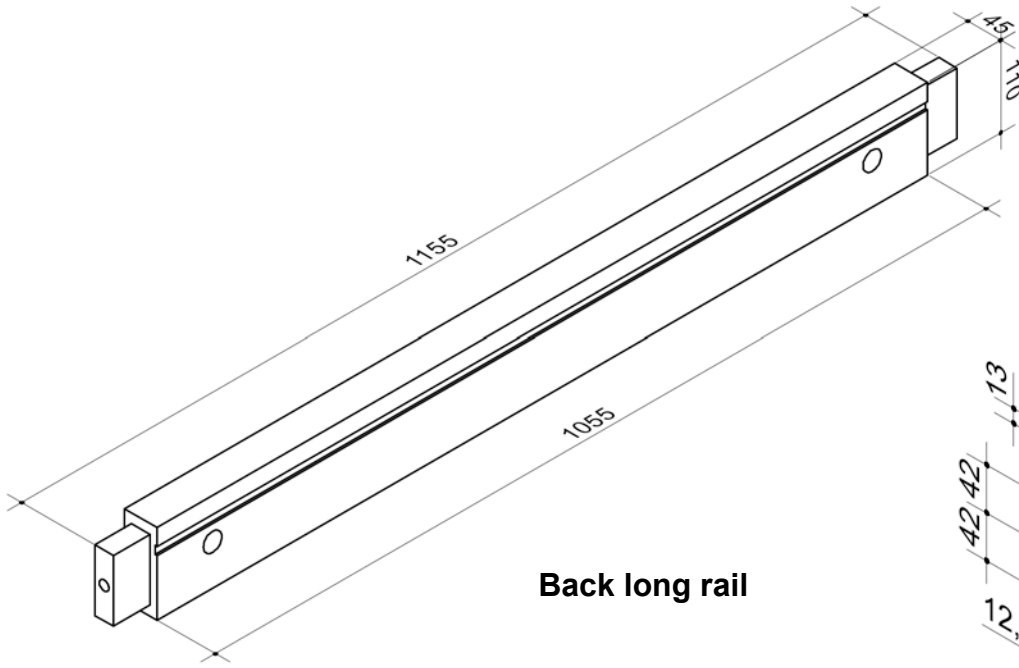

**Back long rail**

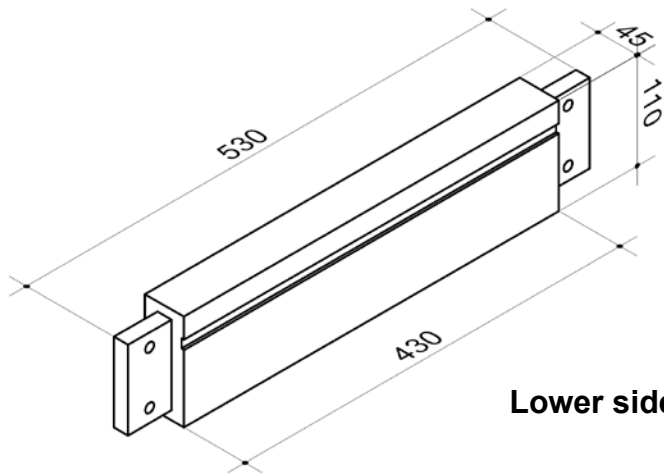
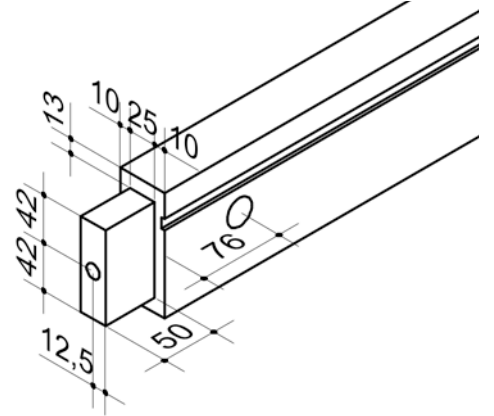

**Lower side rail**

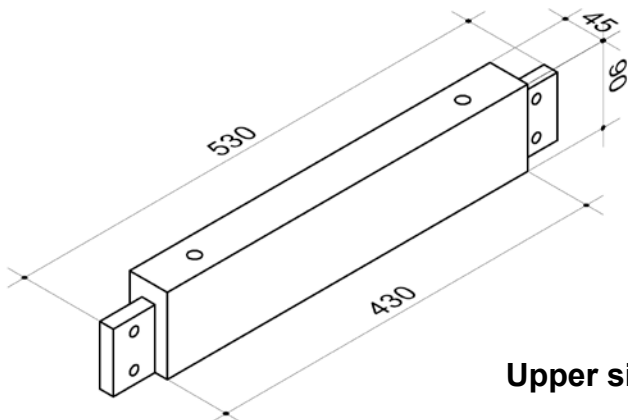
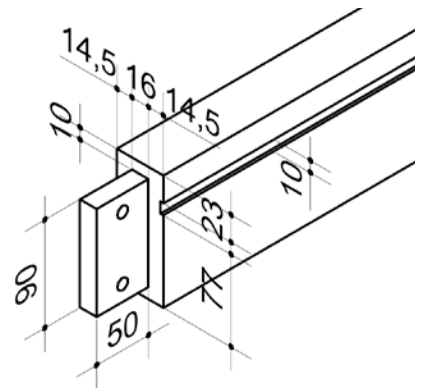

**Upper side rail**

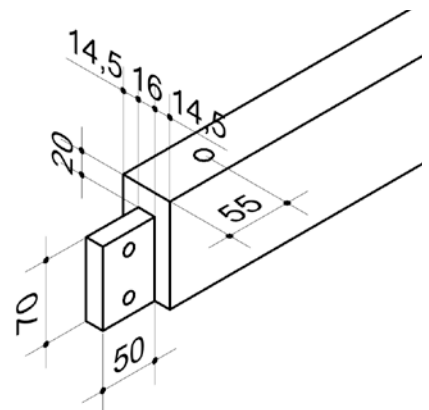





Detail of the front benchtop  
(View from underneath!) with  
dimensions for the cutouts for  
the tail vise mechanism

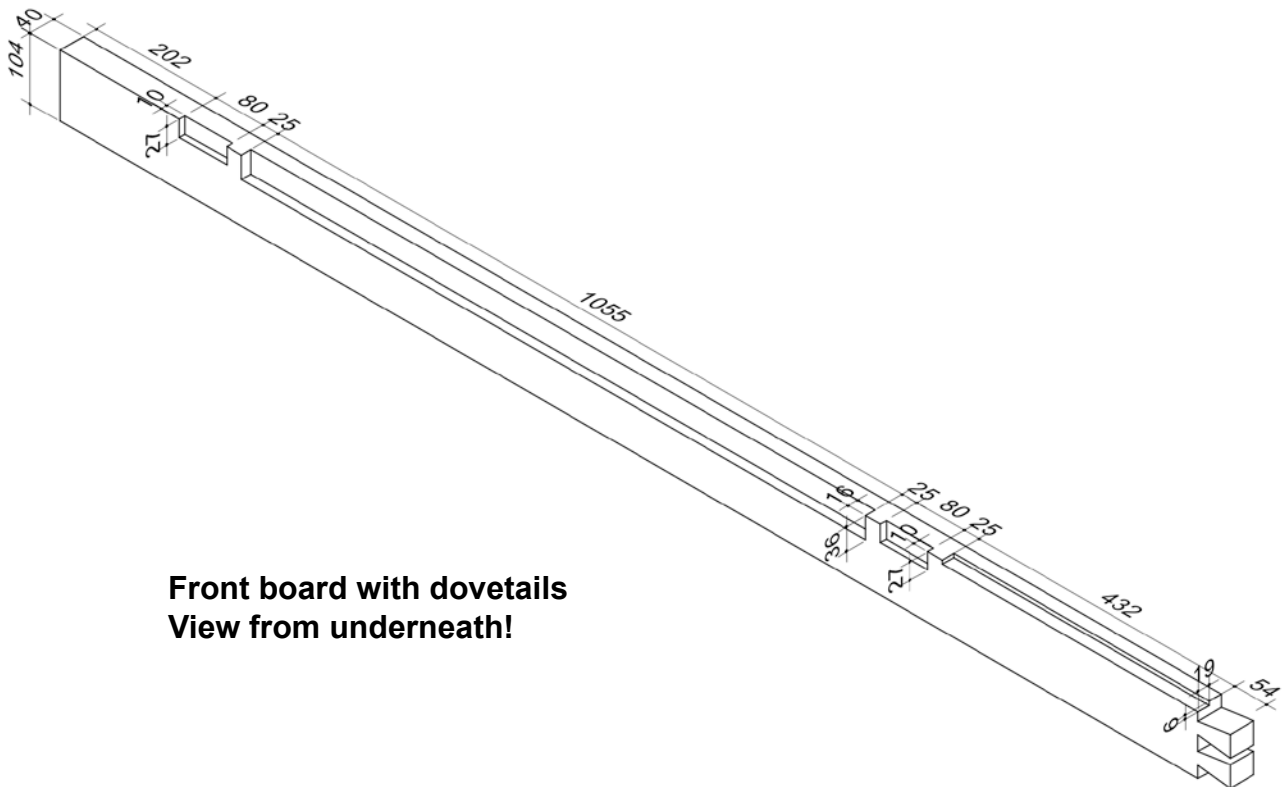
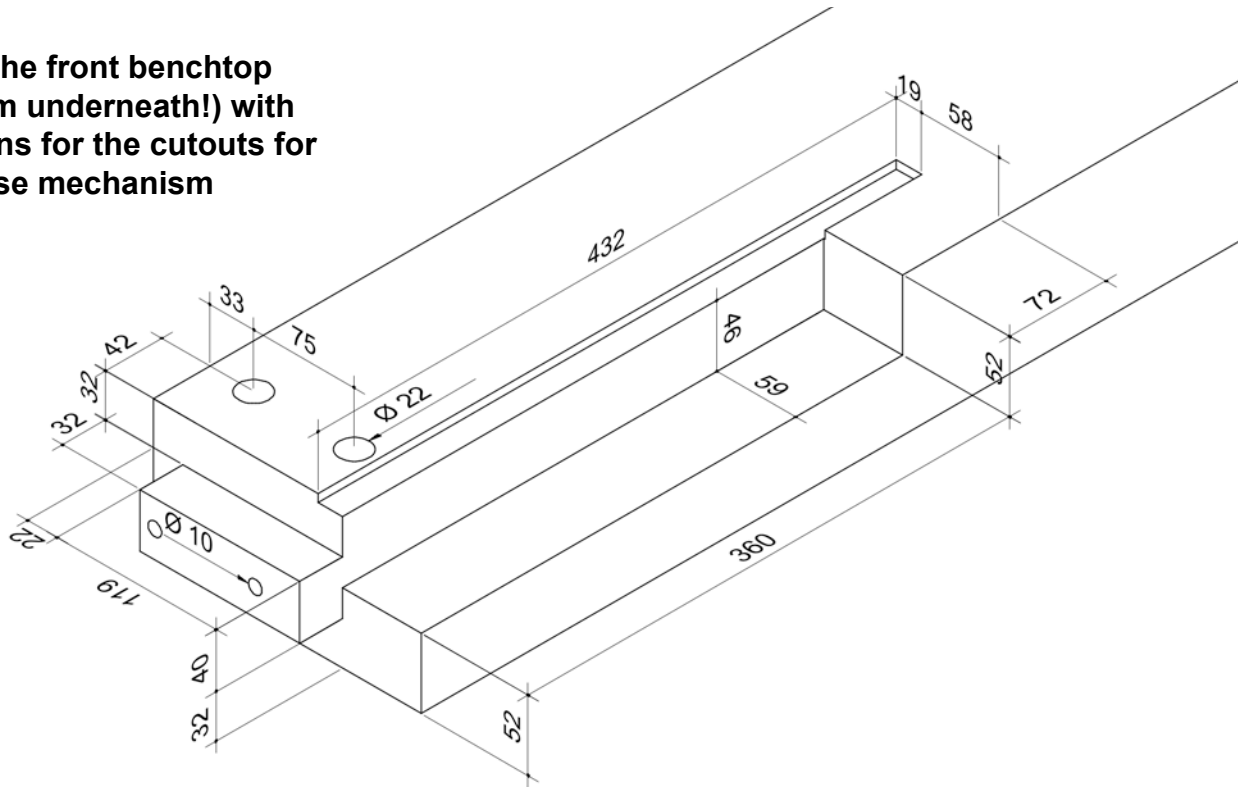

Front board with dovetails  
View from underneath!

# DETAILED DIMENSIONS - UNDER SIDE OF END BOARD (CLAMP)

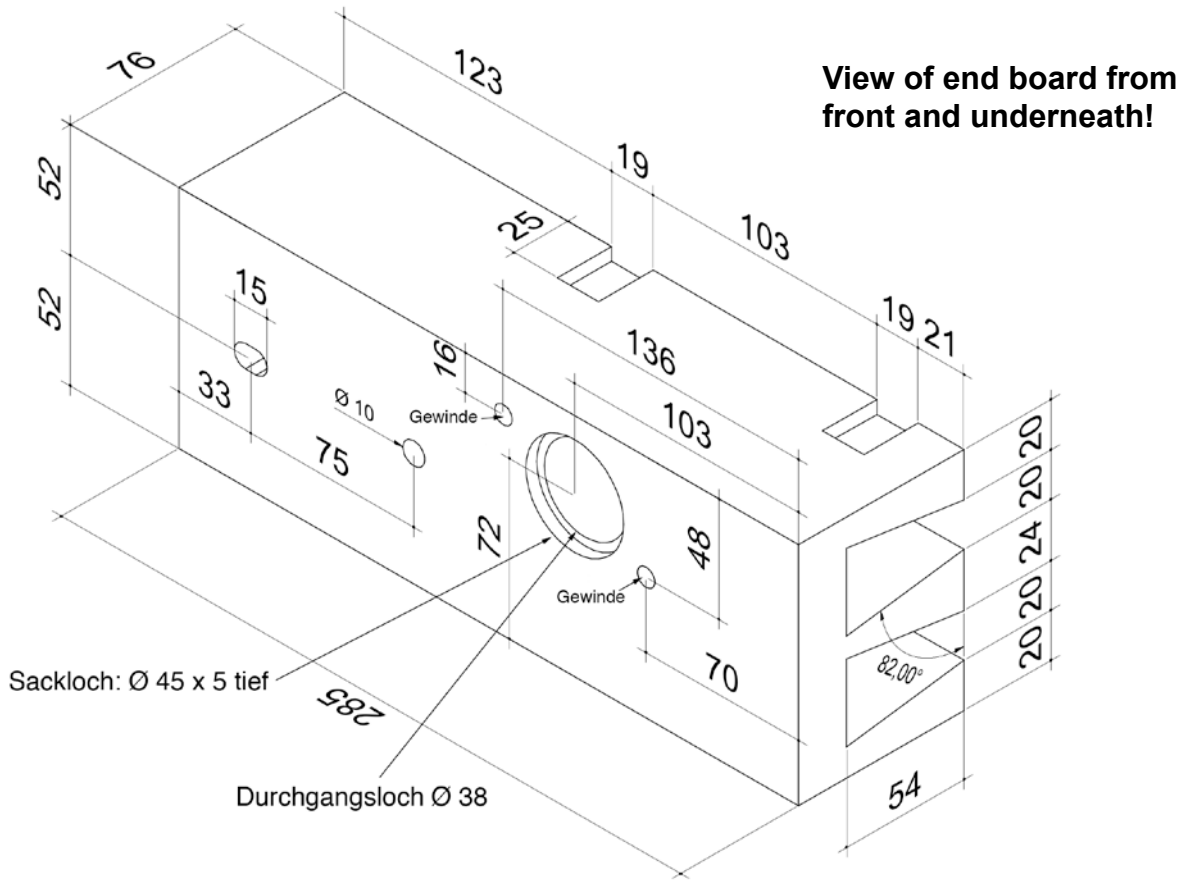

**View of end board from back and underneath!**

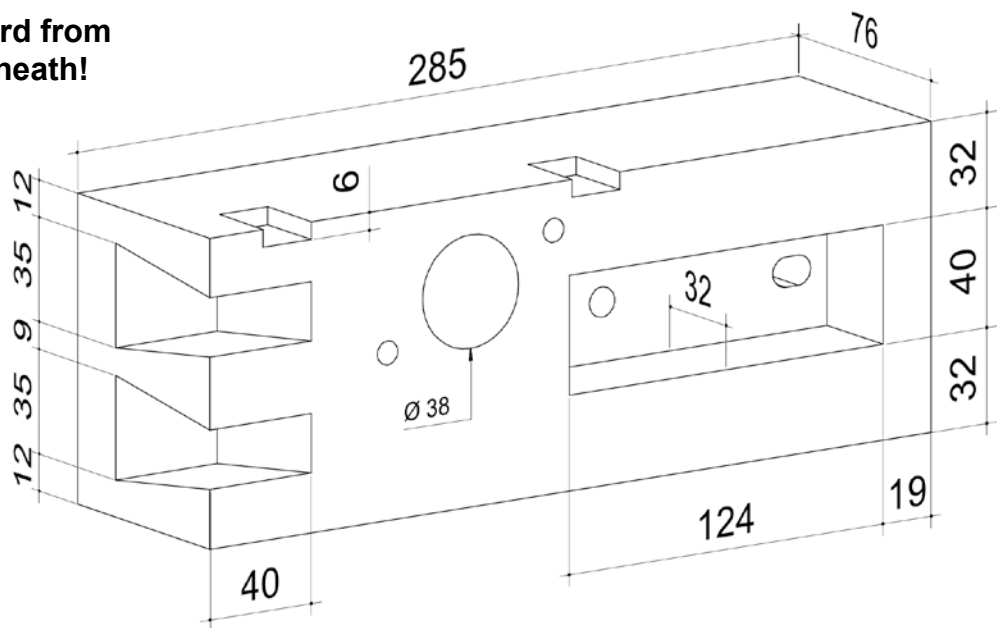



# DIMENSIONS OF THE CHOPS FOR LEG- AND WAGON VISES

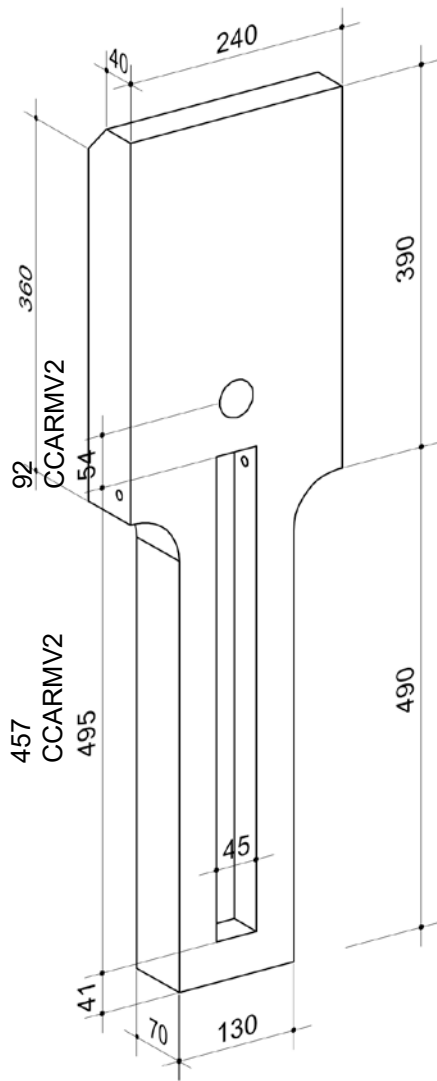

### Chop, rear view

With dimensions of the slot for the "Solo" Crisscross:  
 Routing depth for the slot = 36,5 mm  
 Diameter of the vise screw hole = 38 mm

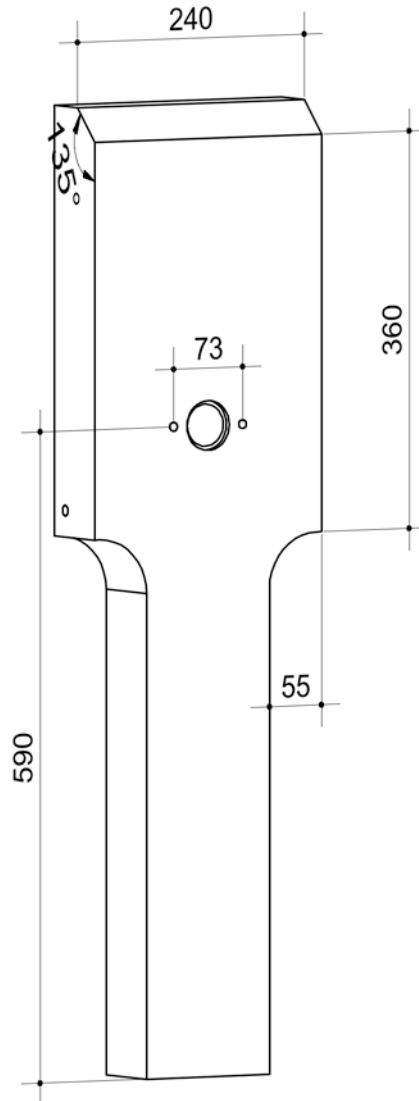

### Chop front view

Hole for vise screw:  
 1. Counter bored hole  
 $\varnothing 45 \times 5$  mm deep  
 2. Vise screw hole  $\varnothing 38$  mm

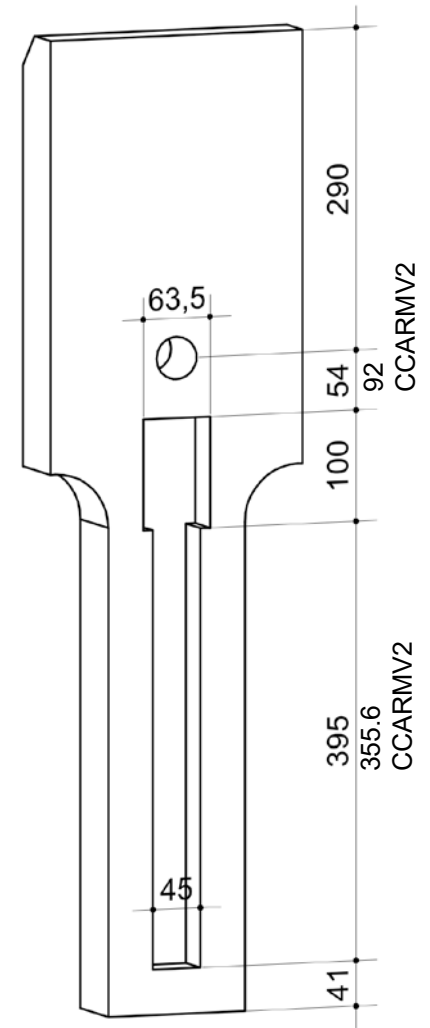

### Chop, rear view

With dimensions of the slot for the "Retro" Crisscross:  
 Routing depth for the slot = 36,5 mm  
 Diameter of the vise screw hole = 38 mm

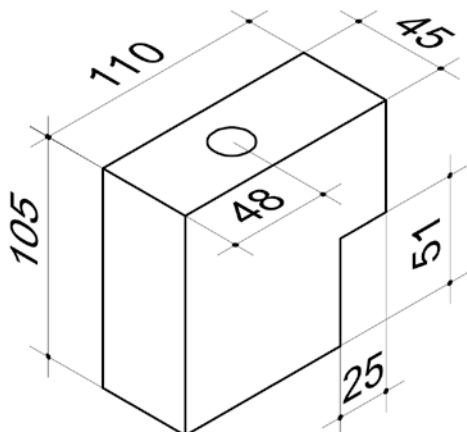

### Chop for the wagon vise

Hole diameter for the round bench dogs = 19 mm  
 With a height of 105 mm, the moving chop will stand proud of the benchtop and can then be planed back precisely to flush and level with the benchtop.  
 The thickness should be such that, without having significant play, the chop can move freely in its slot.

# DIMENSIONS OF DEADMAN AND SHELVES

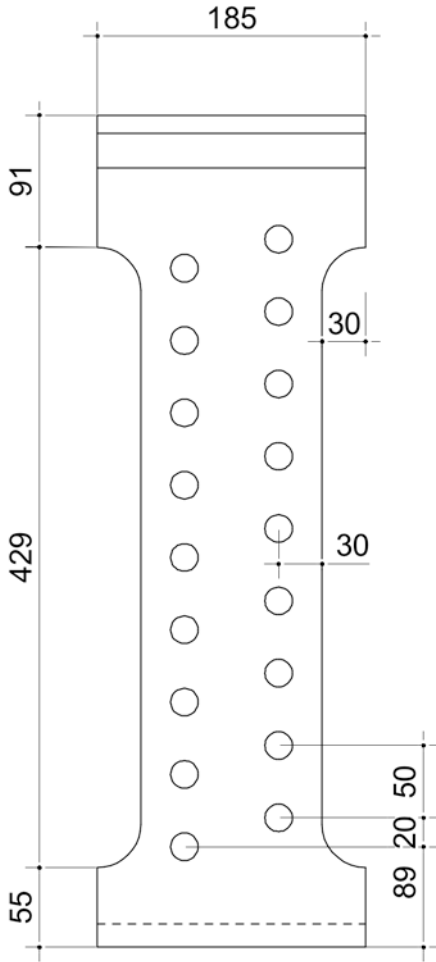

**Front view  
Deadman**

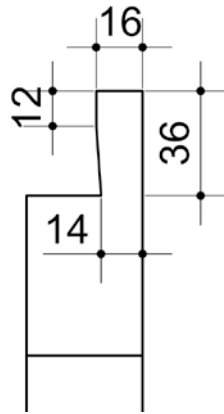

**Rabbit dimensions  
Top of deadman**

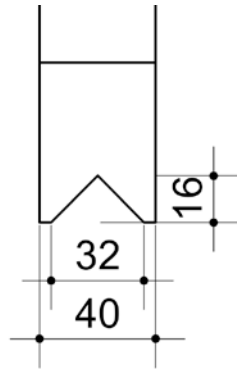

**Slot dimensions  
Bottom of Deadman**

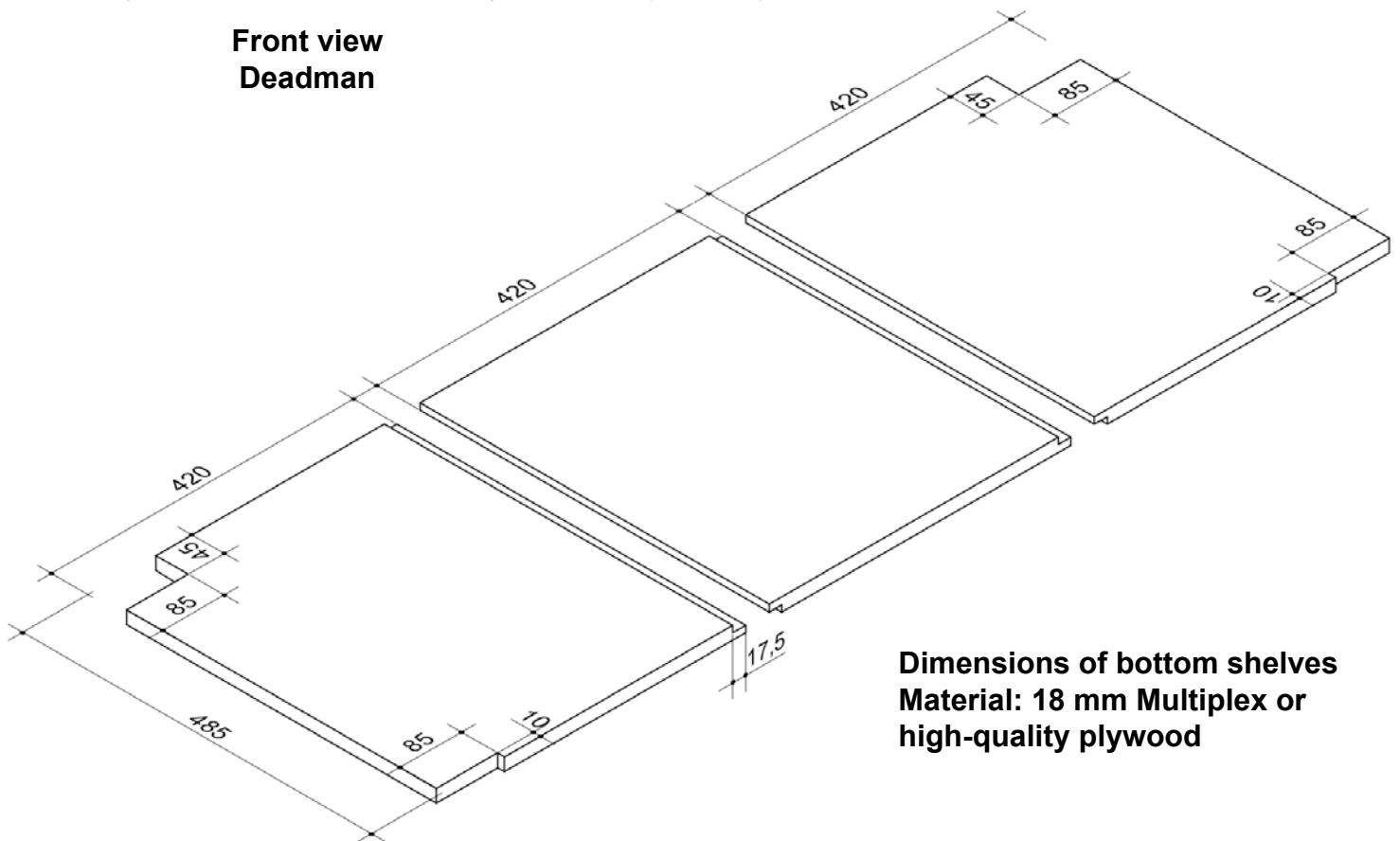

**Dimensions of bottom shelves  
Material: 18 mm Multiplex or  
high-quality plywood**